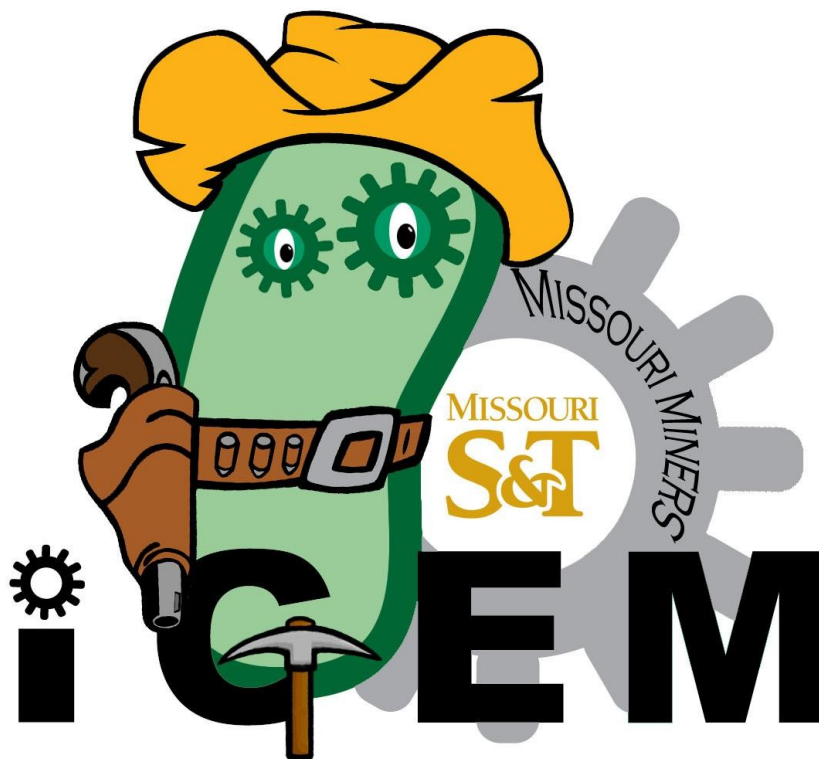


**Missouri S&T iGEM Team  
Lab Training Manual**



### **Third Edition Editors**

**iGEM Students:** Levi Palmer, Kira Buckowing, Kent Gorday, Nocona Sanders, Edna Armstrong, Stephanie Soendker, Austin Hall, Jordan Sanders

### **Second Edition Editors**

**iGEM Students:** Alie Abele, Amanda Foster, David Pohlman, Sarah Rommelfanger, Erica McFarland, Blythe Ferriere, Levi Palmer, Michael Zandstra, Jordan Sanders

### **First Edition Editors**

**Primary Editor:** Alie Abele

**iGEM Students:** Amanda Foster, Erica Shannon, David Pohlman, April Pummill, Blythe Ferriere, Beth Wilkins, Hannah Frye

### **Associate Editors**

**iGEM Advisors:** Dr. Katie Shannon, Dr. Dave Westenberg

**External Contributors:** Vanessa Kaighin, Richard Dalton, Jeanine Bruening, Dr. Ronald Frank

### **Last Updated**

August 2015

### **Edition Number**

## Table of Contents

Introduction.....	1
Lab Map, Safety Equipment, and Waste Disposal.....	2
Lab Map .....	2
Biosafety Levels.....	3
Personal Protective Equipment (PPE).....	4
Spills.....	5
Safety and Emergency Equipment .....	6
Important Numbers .....	7
Waste and Trash .....	7
Personal Conduct and Ground Rules .....	10
Behavioral Expectations.....	10
Lab Cleaning and Organization.....	11
Labeling .....	14
Lab Notebook.....	16
General Lab Technique .....	18
Pipetting .....	18
Aseptic Technique .....	20
Pouring Plates.....	21
Plating and Inoculation.....	22
Concentration Calculations .....	23
Background Information.....	25
DNA (Deoxyribonucleic acid) .....	25
RNA (ribonucleic acid) .....	28
Transcription .....	28
Translation.....	29
Molecular Cloning.....	30
Standard Assembly.....	32
iGEM Protocols and Reactions.....	34
Miniprep.....	34
Restriction Digest.....	37
Ligation .....	40
Transformation .....	41
Chemical Transformation .....	41
Electrical Transformation .....	43
Gel Electrophoresis .....	44
Gel Extraction .....	47
Polymerase Chain Reaction (PCR) .....	48
Sequencing .....	49
Sources.....	50

Appendix A – Glossary.....	51
Appendix B – Egress Map.....	56
Appendix C – Lab Notebook Example.....	57
Appendix D – Preparation and Supplies.....	66
Filling Tip Boxes.....	66
LB Broth.....	66
Pouring LB Agar Plates.....	66
SOB .....	67
SOC .....	67
Antibiotics .....	67
Preparing Frozen Stock Cells.....	68
Making Chemically Competent Cells .....	69
Making Electrocompetent Cells.....	69
Appendix E – Lab Equipment.....	71
Autoclave .....	71
Microcentrifuge.....	71
Mini centrifuge.....	73
Thermocycler .....	74
Water bath.....	76
Stir Plate .....	76
Vortexer .....	76
Microwave.....	77
Incubators.....	78
NanoDrop.....	79
Electroporator.....	80
Gel Electrophoresis Chamber.....	81
Transilluminator .....	83

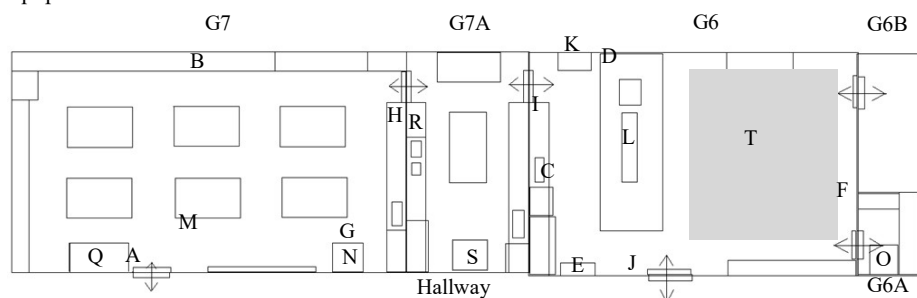
## Introduction

Synthetic biology will revolutionize biotechnology and have a profound impact on the fields of energy, health, medicine, the environment, and more. The International Genetically Engineered Machine (iGEM) Foundation is dedicated to education, competition, the advancement of synthetic biology, and the development of open community and collaboration. The foundation began in January 2003 as a single course at MIT; by 2012 there were nearly 200 teams all over the world. The Missouri S&T iGEM Team and its members are pleased to welcome you. This manual is designed to guide you through the lab training program, which was created to help new members become competent workers within the iGEM lab. This manual will also serve as a valuable reference throughout your time in iGEM. Please note that throughout the manual key words are italicized and defined in the Glossary (Appendix A). We hope you will do well in the lab training program, and that you find this manual instructive.

## Lab Map, Safety Equipment, and Waste Disposal

### Lab Map

The iGEM lab at Missouri S&T is located on the ground floor of Schrenk Hall. iGEM primarily uses G6 for labwork; however, G7 and G7A may be used when available. Below is a map of G6, G7, and G7A. This map includes the location of all safety equipment, as well as equipment used by the iGEM Team, and delineates iGEM space and shared lab space. Before working in the lab, you should be familiar with the location and proper use of all safety equipment in the lab.



#### Map Key:

G7	Molecular Genetics/Microbiology Lab	I	eyewash bottles and fire extinguisher
G7A	prep room	J	fire extinguisher, emergency contact information, and basic lab rules
G6	iGEM lab	K	iGEM supplies shelf (chemicals and kits)
G6A	refrigerator/storage room	L	iGEM micropipettes
G6B	Biology Department storage	M	non-iGEM micropipettes
A	clear-lined autoclave trash bin	N	iGEM freezer
B	glass (and sharps) disposal containers	O	iGEM refrigerator
C	spill response equipment kit (under sink)	Q	37°C shaking incubator
D	MSDS documentation (shelf on end of workbench)	R	37°C stationary incubator
E	iGEM shelf (first aid kit, face shield, gloves, goggles, lab aprons)	S	30°C shaking incubator
F	safety shower	T	non-iGEM lab space (Dr. Thimgan's lab bench and Biology Department storage)
G	safety shower		
H	eyewash bottles		

The egress map for the iGEM lab can be found in Appendix B. You should familiarize yourself with the egress map so that you will be prepared in the event of an emergency evacuation.

## Biosafety Levels

The Center for Disease Control (CDC) has defined four levels of biological containment in labs. Biosafety level criteria, defined by the Center for Disease Control, are set in place to protect lab personnel and the general public from possible harmful bacteria and chemicals. Each level has strict criteria that must be met for the lab to work safely with biological agents in that level. The Missouri S&T iGEM lab falls under Biosafety Level 1 because we only work with well-characterized bacteria and fungi. If the Missouri S&T iGEM team votes to work on a project that involves potentially harmful or pathogenic specimens, the proper updates to the lab or alternate accommodations must be sought to meet the appropriate biosafety criteria.

Biosafety Level 1 is a level of safety appropriate for work done with defined and characterized strains of viable microorganisms not known to cause disease in healthy adults. It is a basic level of containment that relies on standard microbiological practices with no special primary or secondary barriers recommended other than a sink for hand washing. Access to the laboratory can be limited or restricted when experiments or work with cultures and specimens is in progress. Work surfaces are to be decontaminated at least once a day and after any spill of viable material. All procedures should be performed carefully to minimize the creation of splashes or aerosols. All cultures, stocks, and other regulated wastes should be decontaminated prior to disposal by an approved decontamination method (e.g., autoclave).

**Table 1** – Basic description of Biosafety Levels

	Agents Allowed	Practices Required	Safety Equipment Required (Primary Barriers)	Facilities Required (Secondary Barriers)
Biosafety Level 1	Not known to consistently cause diseases in immunocompetent adult humans	Standard microbiological practices	None required	Open bench top, sink
Biosafety Level 2	Associated with human disease; presents danger of percutaneous injury, mucous membrane exposure, ingestion	BSL-1 practices plus: <ul style="list-style-type: none"> <li>• limited access</li> <li>• biohazard warning signs</li> <li>• sharps precautions</li> <li>• biosafety manual defining waste decontamination or medical surveillance policies</li> </ul>	Primary barriers: Class I or II biosafety cabinets or other physical containment devices used for all manipulations of agents that cause splashes or for aerosols of infectious materials; PPE: laboratory coats, gloves, face protection as needed	BSL-1plus: <ul style="list-style-type: none"> <li>• non-fabric chairs and other easily cleanable furniture</li> <li>• autoclave available</li> <li>• eyewash readily available</li> </ul>

Biosafety Level 3	Indigenous or exotic agents with potential for aerosol transmission; disease may have serious or lethal consequences	BSL-2 practices plus: <ul style="list-style-type: none"> <li>• controlled access</li> <li>• decontamination of all wastes</li> <li>• decontamination of lab clothing before laundering</li> <li>• baseline serum</li> </ul>	Primary barriers: Class I or II biosafety cabinets or other physical containment devices used for all manipulations of agents; PPE: laboratory coats, gloves, respiratory protection as needed	BSL-2 plus: <ul style="list-style-type: none"> <li>• physical separation from access corridors</li> <li>• hands-free hand-washing sink</li> <li>• self-closing double door access</li> <li>• unrecirculated exhaust air</li> <li>• negative airflow into laboratory</li> <li>• eyewash readily available in lab</li> </ul>
Biosafety Level 4	Dangerous/exotic agents which pose high risk of life threatening disease, aerosol-transmitted lab infections; or related agents with unknown risk of transmission	BSL-3 practices plus: <ul style="list-style-type: none"> <li>• clothing change before entering</li> <li>• shower on exit</li> <li>• all material decontaminated on exit from facility</li> </ul>	Primary barriers: All procedures conducted in Class III biosafety cabinets or Class I or II biosafety cabinets in combination with full-body, air supplied positive pressure suit	BSL-3 plus: <ul style="list-style-type: none"> <li>• separate building or isolated zone</li> <li>• dedicated supply/exhaust, vacuum and decontamination system</li> </ul>

### Personal Protective Equipment (PPE)

Personal protective equipment (PPE) is used to protect lab personnel from contact with hazardous materials and infectious agents. Proper PPE can also protect the experiment from contamination. The following PPE is recommended for regular use in the iGEM lab:

#### Face Protection

Goggles or safety glasses with solid side shields in combination with masks or other splatter guards are required for anticipated splashes, sprays, or splatters of hazardous material. If you require corrective lenses, eyeglasses are preferred for safety reasons. Contact lenses are acceptable in our lab, but do not insert or remove them while in the lab.

For work with the transilluminator, or photobox, a face shield is required to protect your skin and eyes from UV radiation. The iGEM Team has its own face shield, labeled "iGEM." The location of the iGEM face shield is indicated on the lab map on p. 2.

#### Laboratory Clothing

It is important to wear appropriate clothing in the laboratory to ensure safety, avoid contamination of your work, prevent contamination of the environment, and prevent damage to



street clothes. Appropriate lab clothing includes long pants, closed-toed shoes, sleeves that aren't loose or baggy, and clothes that you do not mind getting dirty or accidentally staining. Do not wear sandals or open-toed shoes in lab. Never go barefoot or only in socks. Wear nice clothing at your own risk. A laboratory coat may be worn in the lab to protect street clothing. Jewelry is acceptable but should not interfere with your movement or have the potential to become contaminated. Long hair should be tied back. If long sleeves are worn, they should not be loose or baggy, as they could interfere with your work, cause spills, aid in contamination, or catch fire. Following these guidelines will help to prevent accidents, damage to clothing, and contamination.

### Gloves

Gloves should be selected based on the hazards involved with the activity to be conducted. Gloves must be worn when working with biohazards, toxics, and other physically hazardous agents. Temperature-resistant gloves should be worn when working with hot material or dry ice. When working with hazardous material, the glove should overlap the lower sleeve and cuff of the lab coat/garment. Double gloving may be appropriate in some instances. If a spill occurs, hands will be protected after the contaminated outer gloves are removed. Gloves should be removed before leaving the laboratory when work with infectious materials is complete. Uncontaminated gloves are disposed of in the lab trash, while contaminated gloves are disposed of in the autoclave trash. See Waste and Trash Table (Table 2) below. Do not wear gloves outside the lab and do not wash or reuse disposable gloves.

More information on lab safety and lab safety regulations can be found on the following website:  
<http://ehs.mst.edu/labsafety/biologicalsafety/index.html>

### **Spills**

#### Chemical spills

Try to anticipate the types of spills that could occur in the lab and understand how to use the proper spill clean-up equipment located beneath the sink in the iGEM lab to respond to a minor spill. The MSDS for the material can be found on the shelf at the end of the workbench next to the chemical storage; it contains specific spill response information. Most chemicals used in the iGEM lab (i.e., growth media, buffers, other kit reagents) are non-hazardous and spills can be safely cleaned up by wiping with paper towels. Used paper towels should be placed in the appropriate trash bin (see the Waste and Trash section). The area should then be rinsed with water.

Only attempt to respond to small spills that you can safely clean up; leave larger spills to knowledgeable and experienced personnel (iGEM lab Instructors, faculty/staff). If a spill is too large for you to handle and there are no Instructors present, immediately call the lab manager for assistance. If there is an immediate threat to your life or another's life, call 911 immediately.

If a chemical comes into contact with your skin or clothing, you may need to use appropriate emergency equipment such as the eyewash station or safety shower. See the Emergency Equipment section below for the proper use of this equipment. The location of this equipment is also shown on the lab map on p. 2.

General precautions for a minor chemical spill:

- Alert people in immediate area of spill.
- Increase ventilation in area of spill (open window, turn on hood).
- Wear protective equipment, including safety goggles, gloves, and long-sleeve lab coat.
- Avoid breathing vapors from spill.
- Use appropriate kit to neutralize and absorb inorganic acids and bases. Collect residue, place in a container, label container as hazardous waste, and contact an Instructor for disposal.
- For other chemicals, use appropriate kit or absorb spill with vermiculite, dry sand, diatomaceous earth, or paper towels. Collect residue, place in container, and dispose of as chemical waste. Paper towels may be disposed of in an appropriate trash bin.
- Clean spill area with water or another appropriate cleaning solution if necessary.

#### Biological spills

If there is a non-hazardous biological spill, first add bleach solution, BacDown, or other disinfectant to the spill. Then clean up the spill with paper towels and dispose of them in a lab trash bin. Make sure to thoroughly wipe the area with disinfectant.

In the event of a biohazard spill, additional precautions will be necessary. However, as a Biosafety Level 1 lab, the iGEM lab does not work with biohazardous material.

## **Emergency Equipment**

#### First Aid Kit

The first aid kit is located on the bottom shelf of the bookcase next to the fume hood in the iGEM lab. Use this for minor injuries like small cuts, burns, or scrapes. For more serious injuries to yourself or others working in the lab, immediately get help by calling 911.

#### Eyewash Bottles and Safety Showers

Eyewash bottles and safety showers are inspected annually by university personnel. If there is a possibility that chemicals may cause damage to the eyes, emergency eyewash bottles are available next to both doorways into G7A, as shown on the lab map on p. 2.

For chemical exposure to large areas of skin, a safety shower should be used. Two safety showers are easily accessible when working in the iGEM lab – one in G7 directly in front of the

fume hood and iGEM freezer, and one in G6 next to the door to G6A. The locations of these showers are also shown on the lab map on p. 2.

#### Fire Safety Equipment

A fire extinguisher is located next to the door to the hallway in the iGEM lab. It is inspected annually by university personnel. In the event of a fire, extinguishing the flame should not be the primary responsibility of any iGEM lab worker. However, if you attempt to extinguish a fire, it is important to understand how to properly operate a fire extinguisher. To use the fire extinguisher, remember PASS - Pull the pin, Aim at the base of the fire, Squeeze the top handle or lever, and Sweep from side to side. **Do not fight fire if you do not have adequate or appropriate equipment, if you might inhale toxic smoke, or if your instincts tell you not to. The final rule is always to keep an exit at your back while attempting to extinguish a flame so that you can escape.**

Note: If the situation poses a threat to anyone's safety, dial 911 and/or use the following contact information as necessary.

#### **Important Numbers**

<u>Missouri S&amp;T Police</u>	(573) 341-4300
<u>Health Services</u>	(573) 341-4284
<u>Environmental Health and Safety Services</u>	(573) 341-4305
<u>Biology Department Office</u>	(573) 341-4831

Personal contact information for iGEM advisors and instructors is posted in the lab beside the hallway entrance to G6, as shown on the lab map on p. 2.

#### **Waste and Trash**

It is important that you be familiar with proper disposal procedures in every lab. You are expected to familiarize yourself with these procedures. Failure to follow them can result in a hefty fines that iGEM cannot afford to pay. Waste and trash streams are outlined in this section. Table 2 outlines various waste and trash streams relevant to the iGEM lab.

**Table 2 – BIOLOGICAL LABORATORY DISPOSAL STREAMS\***

<b>CATEGORY</b>	<b>DESCRIPTION</b>	<b>CONTAINER</b>	<b>LOCATION</b>	<b>HANDLING</b>	<b>ROUTING</b>
Non-recyclable Waste Glass	Plate glass, Pyrex, light bulbs, broken glass chemical containers, <b>Uncontaminated**</b> plastic serological pipettes	Tall cardboard container with heavy plastic liner	Under the lab bench across from the white board in G7	Removed by custodial staff when full	Solids (not recyclable)
Empty Chemical Containers	Intact, clean triple-rinsed glass and plastic (#1 and #2) containers; recyclable <b>without caps</b>	Plastic recycling bin	Corridor across from 105 Schrenk	Removed by custodial staff when full	Recyclable
Lab Trash	<b>Uncontaminated**</b> gloves, bench paper, packaging materials, foil, plastic bags, paper towels, weighing boats, bottle caps, fly media, fly embryo plates, culture plates (with or without media); culture and centrifuge tubes (with or without media), filter flasks	Standard trash can with 4-mil liner	Lab	Removed by custodial staff when full	Solids
All sharps	All Pasteur and other <b>glass</b> pipettes, needles, syringes, scalpel blades, razor blades, slides, cover-slips	Tall cardboard container with heavy plastic liner	Under the lab bench across from the white board in G7	Removed by custodial staff when full	Solids (not recyclable)
Contaminated Trash	Experimentally cultured stocks, plates or other materials meeting definition (See *** below)	Clear plastic lined autoclave trash bin or small, bench-top container****	Next to the hallway door in G6 or G7	Autoclave-certified lab personnel will autoclave and dispose of when full	Autoclave Trash

\* Does not include radioactive or hazardous chemical waste

\*\* "Uncontaminated" applies to any material not having been in contact with an infectious agent. Although the *E. coli* strains we work with are not infectious, we will handle them as if they were infectious agents.

\*\*\* Contaminated trash is any lab trash which has come in contact with bacterial cultures.

\*\*\*\* Any containers MUST be labeled "contaminated trash" or "autoclave trash". Transfer contaminated materials to the autoclave trash bin when the small container is full.

**Note:** "Waste" refers to chemical or hazardous materials that need to be disposed of following specific government safety regulations. Contaminated trash is not considered

waste; therefore, be sure to label contaminated trash containers as such and NOT as waste. Incorrect labeling could lead to expensive fines for the team. The following paragraph is Missouri S&T's official statement on chemical waste. The iGEM lab generally does not generate chemical waste, but it is important to be familiar with the definition of chemical waste and the difference between chemical waste and other types of lab waste and trash.

*Laboratory chemical waste must be disposed of in accordance with local, state, federal, and Missouri S&T requirements. Specific guidance on how to identify, handle, and request disposal pickup can be found in the Chemical Waste section of the Waste Management Program available at the EHS website. All waste must be tagged with chemical waste tags (available from EHS). These tags should be filled out and dated with the accumulation start date, the generator's name, location of waste, and contents of waste container. Missouri S&T policy limits the storage time for waste in laboratories and other areas to a maximum of 90 days. Waste containers must be closed unless waste is being added or removed and stored properly until pickup.*

## Personal Conduct and Ground Rules

### Behavioral Expectations

You are responsible for maintaining an enjoyable and safe environment in the iGEM lab. Unsafe practices endanger not only you but the people around you, the success of your experiment, and the lab equipment as well. Read the following safety information carefully, and review applicable safety information before you begin each day's work. If you have any questions about safety or laboratory procedures, be sure to ask an iGEM lab Instructor and/or research the appropriate protocols before entering the lab. The following is a list of expectations for behavior in the lab, but this list is not comprehensive. Use good judgment at all times and be respectful to your lab mates and the lab equipment.

1. Be prepared to work when you arrive in the laboratory. Be sure that you understand the procedure to be employed in your work and the possible hazards associated with it. If you have any questions, consult the Lab Training Manual and/or ask an iGEM lab Instructor.
2. Be serious and alert when working in the laboratory. Never "horse around" in the laboratory.
3. Be respectful of the work of your lab mates and do not distract them or get in their way. Speak and act respectfully and professionally to all lab mates, regardless of personal or social matters.
4. Never eat or drink in the lab or on laboratory equipment. Avoid chewing gum or biting fingernails. Never touch face, mouth, nose, or eyes in lab. Do not apply cosmetics in the lab. Do not pipette by mouth.
5. Keep lab station clear of any unnecessary notebooks, papers, and equipment to minimize the risk of spills or damage to equipment and documents. Do not leave backpacks, purses, laptop cases, etc. in walkways or on lab benches.
6. Never handle any equipment unless you have been properly trained in its use. Most of the lab equipment is expensive; iGEM cannot afford to replace or repair it.
7. Do not take equipment out of the lab.
8. Do not use iGEM lab equipment or materials for anything but iGEM work unless you have received permission from the President or Lab Manager.
9. Handle scalpels or razor blades with extreme care. Never cut material toward you; cut away from you.
10. Never attempt a procedure you are not sure how to perform, and always read the entire procedure before starting.
11. Clean up after yourself. Do not leave your workstation unless bench is clean and sterile and all materials have been returned to their appropriate storage location. Leave the lab clean and ready to be used by your lab mates. If you do not have time to clean up after yourself, then you do not have time to do lab work.

12. Please note that G6 is a shared lab used by both iGEM and Dr. Thimgan's research team. Be respectful of their space, equipment, and time working in the lab. G6 is also a storage room for the Biology Department, so also be respectful of stored equipment and materials.

**13. When in doubt, ask! If there is anything you are unsure about, ask an instructor. They are there to help and maintain an educational and productive lab experience.**

### Lab Cleaning and Organization

You are expected to clean up after yourself in the lab. This is a part of lab work. It is absolutely unacceptable to leave the lab messy or disorganized. You should leave the lab at least as clean and organized as you found it. The following are guidelines regarding lab cleanup.

#### Glassware storage

- Clean, dry glassware, including clean autoclaved glassware, goes in the upper cabinet to the right of the sink.
- Clean, wet glassware goes on the drying rack above the sink (not on the blue mat to the right of the sink).
- Dirty or used glassware can temporarily go on the blue mat (not in the sink). Do not leave the lab without washing your dirty dishes.
- Clean glassware that needs to be autoclaved goes in the box at the end of the counter that has the "to be autoclaved" label in front of it.
- Glassware containing used, old, or contaminated media goes in the box at the end of the counter that has the "to be autoclaved" label in front of it.
- Glassware containing unused, autoclaved media goes on the shelf labeled "media" on the bookshelf by the door to G7.
- All tubes, whether clean, dirty, or containing media, should be put in a tube rack. Don't just leave them to roll around.

#### Glassware cleaning

If your glassware contains old, contaminated, or used media, have an Instructor or other qualified individual autoclave it, media and all. Do not attempt to autoclave it yourself. Then proceed to the following steps:

1. Rinse glassware with plenty of tap water. A little bit of soap may be used for difficult to clean glassware. Too much soap will be difficult to rinse out and could affect future experiments.
2. Rinse glassware again with distilled water, which comes from the faucet with the white handle that will not stay on when released.
3. Allow glassware to dry on the drying rack.

4. Autoclave glassware if necessary. Most glassware doesn't need to be autoclaved after washing, but if you are unsure, ask an Instructor.
5. Put glassware away in cabinet. If you see dry glassware on the drying rack, please put it away even if it is not yours.

#### Reaction Kits

- Kits and all of their reagents should be put back where you got them when you have finished using them. This means that if one of the kit's reagents was in the refrigerator, then that reagent should go back in the refrigerator.
- Kits can generally be located on the supplies bookshelf, on the shelf labeled "kits."

#### Chemicals/Reagents

- On the supplies bookshelf, there is a shelf labeled "aqueous solutions." All non-refrigerated iGEM aqueous solutions should be stored here. There is also a shelf labeled "dry chemicals/reagents" where all non-refrigerated iGEM dry chemicals and reagents should be stored.
- Some solutions or dry chemicals need to be stored at 4°C or -20°C. These will be stored in the iGEM freezer or iGEM refrigerator, which are both shown on the lab map on p. 2.

#### Pipette and Pipette Tips

- Autoclaved pipette tips go on the shelf labeled "pipette tips" on the supplies bookshelf.
- Empty tip boxes go on top of the bench shelf over the label "empty tip boxes."
- For filled tip boxes to be autoclaved, place autoclave tape on the box, then place box on top of the bench shelf over the "full tip boxes to be autoclaved" label.
- When autoclaved tips get low, refill some tip boxes and place them in the "full tip boxes to be autoclaved" area.
- Used tips go in the various receptacles on the bench labeled "contaminated trash" or "autoclave trash."

#### The Bench

- Sterilize the lab bench surface before and after you use it.
- When you are finished using the lab bench, it should be cleared, e.g., no tip boxes, tubes, plates, etc. lying around.
- There should **never** be food or drink on the lab bench.

#### The Refrigerators and Freezers

- We share refrigerators and freezers with other labs, so if you're not sure if something in them is ours, don't touch it.
- Make sure doors are securely closed each time you access them. Samples can be ruined and the compressor can break if the doors are left open.



- If you have to move anything around to find a sample, make sure you put everything back where it was before so other people can find their samples.

#### Miscellaneous

- There is a scale in Dr. Westenberg's lab that can be used if more sensitive weighing is required than our scale. This scale should **never** be moved because it has sensitive calibration.
- The mini centrifuges are in G7 and should never be relocated.
- If you borrow a chair, equipment, chemicals, etc. from another room (such as G7 or Dr. Westenberg's lab), put it back where you found it as soon as you're done using it.

## Labeling

Several people will be sharing the iGEM lab and working on projects together. In order to help things run as smoothly as possible, labeling practices **must** be consistent. The following tables describe how various types of media and samples should be labeled. Poor labeling can lead to confusion and ruined experiments.

Media codes and antibiotic codes are used in conjunction with each other. For instance, LB + ampicillin plates are marked with BOTH a single yellow line and a single back line.

**Table 3** – Shorthand for Reactions

Reaction or Procedure	Shorthand
Chemical Transformation	CT
Electrical Transformation (Electroporation)	ET
Ligation	L
Restriction Digest	D
Miniprep (plasmid purification)	Mp
Genomic DNA Purification	Gp
Making electrocompetent cells	E and a dot
Making chemically competent cells	C and a dot
Gel Extraction (gel purification)	GE
Frozen Stock Cells	S
PCR (DNA amplification)	A
Isolation (streaking)	I
Broth Culture	BC

**Table 4** – Antibiotic and Chemical Codes

Antibiotic or Chemical	Marking
Ampicillin	1 black line
Chloramphenicol	3 red lines
Tetracycline	2 black lines
X-gal	1 red line
Kanamycin	3 black lines
Gentamycin	2 red lines

**Table 5 – Media Codes**

<b>Media Name (Media Abbreviation)</b>	<b>Marking Code</b>
Non-nutritive Agar (AG)	1 brown line
Yeast Extract-Mannitol (YEM)	1 orange line
Luria Broth (LB)	1 yellow line
Trypticase Soy Agar (TSA)	1 green line
Nutrient media	1 black line
Glucose-Salts-Yeast Extract (GSY)	2 black lines
Dr. W's Luminescent	1 green line, 1 brown line

This labeling applies to all types of containers, including plates, tubes, Epis, PCR tubes, etc. Each of the following must be included to ensure that each sample has a unique label:

1. The date the reaction or procedure that produced the sample was performed.
2. The code of the reaction that **produced** the sample, as determined by the reaction shorthand table (Table 3).
3. The number of the sample. In the lab notebook, within the entry for the reaction, include a table of the samples produced by that reaction. Number each sample and include a brief description of each sample in this table. The requirements for the table are detailed in Appendix C. Samples from each type of reaction (e.g., digestion) will have continuous numbering within each day, even if the same type of reaction is performed by different people within the day. Numbering will be restarted each day.

Example: If Alie produces four digestion samples in the morning and Erica produces two digestion samples in the afternoon of the same day, the sample labeling would be as follows: 1/23/13 D 1, 1/23/13 D 2, 1/23/13 D 3, 1/23/13 D 4, 1/23/13 D 5, 1/23/13 D 6. See Appendix C for a complete example of a lab notebook entry demonstrating correct labeling practices.

We are aware that reactions performed in the lab may not be limited to those on the reactions shorthand table (Table 3). You may make new shorthands for non-standard reactions, but be sure to note these in the lab notebook. If you are unsure about a reaction's shorthand, ask an Instructor for help.

## Lab Notebook

This section outlines standard practices used for writing in a laboratory notebook. In the iGEM lab, you are expected to follow these practices, as well as the format and details shown in the lab notebook example in Appendix C. As a Trainee and a Dependent Lab Worker, you will be expected to keep your own personal lab notebook for iGEM labwork. As an Independent Lab Worker, Assistant Instructor, or Instructor, you will be expected to record all iGEM labwork that you or Dependent Lab Workers perform in the official iGEM lab notebook.

### Handwriting

1. No cursive.
2. No block lettering.
3. Write only in blue or black pen, never in pencil.
4. Handwriting **must** be neat and legible.

### General Lab Notebook Rules

1. Every entry will start with the date and the name of the person making it.
2. All entries should be entered into the notebook in the order in which they were performed.
3. Every reaction description will start with the time the procedure or reaction was started and the time it was completed.
4. Any and all errors will be drawn through with a **single** line (for text) or a **single X** (for pictures/figures/charts). Do **not** scribble out or whiteout any item in the notebook.
5. Any and all corrections will be initialed and dated by the person making the edit.
6. There is no need to cram your entries into inadequate space. Another notebook can always be provided if the first gets filled up.
7. **Never** remove a page from the lab notebook.

### General Contents of an Entry

1. Each reaction performed should be described, including the exact amounts, protocols used and any deviations.
2. Entry should include any and all notes regarding labeling and location of samples (write exactly how the sample is labeled and where it is stored once the reaction is complete).
3. Entry should make note of any accidents.
4. Entry should make note of anything that may affect the outcome of a reaction (eg. centrifuged too long) and the affected sample(s) should be noted in the notebook.
5. Reactions and their details should be entered within the notebook entry in the order in which they occurred.
6. If you needed to know it to do the reaction, you should include it in the notebook (eg. concentrations, amounts, times).

### Miscellaneous

1. Ask an Instructor or Assistant Instructor present to review your entry.
2. Make sure to leave ample time to make your entry. The quality of the work you do is more important than the amount of work you do.

3. If you run a gel, save the picture and email it to the Lab Manager. Box off a space in the notebook and write (inside the box) what should be put there. The email should include enough information to match the picture to the appropriate box. The Lab Manager will print and paste the gel picture into the notebook.

## General Lab Technique

### Pipetting

The micropipette is one of the most important tools in the iGEM lab and is used for various procedures. All students working in the iGEM Lab must understand how to use a pipette properly. There are five pipettes in the iGEM lab for use with different ranges of volumes under 1 mL (1000  $\mu$ L). These volume ranges are printed on the blue plastic body of the pipette. The color of the knob on top of the plunger of the pipette corresponds to the range. For volumes between 200 and 1000  $\mu$ L, use the blue pipette; for 20 to 200  $\mu$ L, use the yellow pipette; for 5 to 50  $\mu$ L, use the orange pipette; for 0.5 to 10  $\mu$ L, use the gray pipette; and for 0.2 to 2  $\mu$ L, use the pink pipette. The volume is adjusted by twisting the colored knob. The volume is displayed on the side of the body through a clear plastic window. Be sure to note the different increments displayed on each pipette. Disposable pipette tips must be attached to the end of the white plastic shaft to dispense liquids. There are three sizes of tips – 0-1000  $\mu$ L, 0-200  $\mu$ L, and 0-10  $\mu$ L. Tips are ejected from the shaft by pressing the eject button below the plunger.

Pipette technique is a crucial skill. If you don't learn good pipetting technique, it will be nearly impossible to perform any procedure in the lab. The basic steps for using a micropipette are:

1. Select the appropriate pipette for the volume you are pipetting. As a general rule, select the smallest pipette with a range that includes the volume that you are going to pipette.
2. Locate an appropriate box of sterilized pipette tips that will fit securely on the shaft of the pipette that you have selected.
3. Turn the knob to adjust the volume setting of the pipette. Do NOT turn the knob of the pipette past its range limits. The knob can be turned past the limits, but this will ruin the calibration of the pipette, which is expensive to fix. The adjustment knob follows the "left-loosey, righty-tighty" rule.
4. Grasp the pipette with the eject button closest to your thumb. The curved plastic hook opposite the eject button should rest on your index finger.
5. Open the tip box and insert the end of the shaft into a tip, tapping the tipped pipette lightly in the rack to ensure the tip is securely in place. Close the lid of the tip box immediately after tip removal.
6. Before inserting the pipette tip into the sample, gently press down on the plunger with your thumb until you first feel resistance. This is the first of two "stops." Surpassing the first stop will lead to an incorrect volume when retrieving the sample.
7. With the plunger depressed to the first "stop," insert the tip into the sample far enough to access the sample without also collecting air bubbles. Be careful to avoid contact between the shaft of the pipette and any sample containers.

8. Slowly release the plunger to retrieve the sample and remove it from the container.
9. Position the loaded pipette over the receiving container. Slowly depress the plunger to the first "stop" to expel the sample. Continue to press the plunger all the way down to the second "stop" to blow out any remaining sample from the tip.
10. Remove the tip from the sample before slowly and completely releasing the plunger.
11. Eject the used tip into an appropriately labeled trash container by pressing the eject button with your thumb.

The iGEM team has at least one of each of the five pipettes listed above, but if multiple people need to use pipettes at the same time, additional pipettes are located in G7. After using **any** pipettes, they should be put back exactly where they were found. The following techniques should be observed at all times to prevent damage to the pipettes and ensure quality lab work. Pipetting can be one of the most prominent sources of error due to improper use and/or calibration.

#### Pipette Technique Tips:

- **Always make sure to observe the volume range of the pipette before use and while adjusting the volume.** Turning the dial of a pipette past the upper or lower limit will permanently disrupt the calibration of the pipette.
- **Use a constant plunger speed and pressure**, especially with viscous solutions. Retrieving and dispensing samples too rapidly can lead to the sample entering the pipette chamber. Fluid in this chamber can result in pipette inaccuracy and contamination. **Contamination can ruin a pipette. These are expensive pieces of equipment, which we cannot afford to replace on a regular basis. Be especially careful not to allow any liquid to enter the pipette chamber.**
- **Never lay a pipette containing a sample on its side.** Chamber contamination can result.
- Avoid touching the side of a tube unless you are ejecting the sample. Touching the tip against the side of a tube while drawing a sample will lead to an inaccurate sample volume.
- Examine pipette tip before dispensing sample. Make sure that no air bubbles are present in the sample, and that the full sample volume was drawn up.
- Examine the pipette tip after dispensing the sample to ensure that the full volume of the sample was ejected.
- Always hold a loaded pipette in an upright position (within 20 degrees of vertical). Surface tension causes the sample volume to vary if the angle varies.
- Keep tip in sample for one or two seconds after dispensing sample. The amount of liquid in the tip "bounces" slightly when the plunger stops. Slow, even plunger release and a pause after dispensing will minimize errors resulting from this phenomenon.
- Place pipette down between sample deliveries. The heat from a hand will be transferred to the pipette, disrupting the temperature equilibrium and affecting sample volume.

## Aseptic Technique

Aseptic technique is imperative in any microbiology laboratory. Failure to adhere to proper aseptic technique in the iGEM lab can lead to DNA contamination, a very costly error. You could finish an entire project before you notice the contamination in results or sequencing. Contamination cannot be corrected; the only option is to start over.

Aseptic technique refers to procedures by which cultures may be manipulated without infecting workers, contaminating cultures, or contaminating the environment. Because the *E. coli* that we work with is non-pathogenic, worker infection is not a significant concern, but the potential for contamination remains. Because contaminating agents are everywhere (including lab benches, tools, table tops, and skin), do not allow instruments to come in contact with these things. When working with agar plates, pipettes, wire loops, etc. you should be sure that the functioning parts of these items are sterile prior to use. It is necessary to make sure that sterile items do not touch contaminated surfaces or tools. Aseptic technique is always important, especially when using media that does not contain antibiotics.

**Note:** If you are not sure whether your pipette tip is sterile, trash it and get a new one. If you are not sure if your loop is sterile, flame it again.

The mouths of tubes and flasks must always be flamed whenever media is to be poured from them (e.g., pouring plates). Flaming tubes should be routinely done when caps are removed and replaced during transfer of cultures. The purpose of flaming is not to sterilize the glass, but to warm the tube and create warm air convection currents up and away from the opening. This "umbrella" of warm, rising air helps to prevent the entrance of bacteria from the air.

Petri dish lids prevent dust from falling directly onto plates while allowing air diffusion around the edges. Contamination of a lidded plate is rare because there are no direct air currents into the plate.

Whenever a lid is removed, it should be held closely over the plate as a shield. Do not place lids on the bench top. Do not leave plates uncovered. Do not move an open plate.

When working with cultures in test tubes, work as rapidly as is consistent with careful technique. Keep the tubes open a minimal amount of time. While the tubes are open, hold them



at an angle so that dust cannot easily fall into the open tube. Hold the tubes away from your face while uncapped. Avoid talking or breathing in the direction of uncapped test tubes.

Recommendation for handling test tubes (for a right-handed person):

1. Hold the test tube in the left hand.
2. Hold the instrument (loop, pipette, or needle) in the right hand.
3. Grasp and remove the test tube cap with the little finger of the right hand.
4. While continuing to hold the cap with the little finger, lightly flame the tube and use the instrument in the right hand. Never insert the instrument into the tube past the sterile portion of the instrument, tilt the tube until the liquid can be reached by the sterile portion of the instrument.
5. Flame the tube, replace the test tube cap and place the tube into the tube rack.

**Always** clean all work areas (bench, sink area, balance area, other equipment surfaces, etc.) thoroughly before leaving the laboratory. The last step before leaving the lab is to wash your hands.

## Pouring Plates

Plates, or Petri dishes, are commonly used for growing microbial cultures on solid media. The solidifying agent for solid media is agar, which will dissolve into solution at 100°C and cause the media to congeal when it cools to 32-45°C. See Appendix D for recipes and instructions for making solid media for plates. These steps should be followed when pouring plates:

1. Label sterile plates to indicate media and antibiotic. (see the Labeling section).
2. Stack 5 to 6 plates lid-side up on the bench next to a flame and near the edge of the bench. Stacking plates reduces the formation of condensation. Pouring plates next to a flame reduces risk of contamination. Pouring near the edge of the bench allows for effective manipulation of the flask.
3. Remove lid of flask containing molten media and flame its mouth periodically.
4. Starting with the bottom plate and moving up the stack, pour plates one at a time. Fill each plate ~1/2 full. Remember aseptic technique: keep the lid of each plate (and the rest of the stack above it) close over the base of the plate as you are pouring.
5. If air bubbles form, pop them with a sterile nicrome loop. It is difficult to spread bacterial culture over solidified air bubbles.
6. Allow plates to cool at room temperature until media fully solidifies and condensation dissipates.
7. When plates have cooled, put them back into their sleeve, lids down, seal the bag, and label with media, antibiotic, and date.
8. Store plates in iGEM refrigerator (see lab map on p. 2).

## Plating and Inoculation

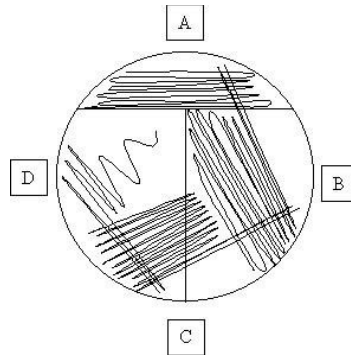
### Plating with beads

1. Pipette the cell solution onto a labeled agar plate.
2. Pour 5-10 sterile glass beads onto the plate.
3. Replace the plate's lid and roll the beads around the plate by shaking back and forth (not in circles) so that the solution is evenly spread across the plate.
4. Dump the beads in a container labeled "used glass beads" located on the lab bench.
5. Replace the plate's lid.
6. Incubate the plate lid-side down.

### Plating with a wire loop

For plating with a wire loop, refer to the diagram to the right and follow the steps below. The purpose of this procedure is to reduce cell density so that an individual colony can later be isolated. This is also called streaking for isolation.

1. Label the plate.
2. Flame the loop, allow to cool, then dip the loop into the broth culture or touch a single colony. Then spread densely over a small region near the edge of the plate (region A in the diagram).
3. Replace the plate's lid and flame the loop.
4. Wait for the loop to cool, then proceed to spread the next region in the diagram by drawing the loop through a small portion of the previous region and spreading it over a fresh region of agar.
5. Repeat steps 3 and 4 until you have spread all the regions shown in the diagram.
6. Replace the lid of the plate.
7. Incubate the plate lid-side down.



### Isolating and screening colonies

A colony is a circular microbial growth on a media plate. When inoculating cultures, always only use cells from a single colony. Isolating a single colony is important because a colony originates from a single cell, which helps ensure that the isolated cells all have the same DNA.

Sometimes bacterial growth is too dense to isolate a single colony. This is called "lawn growth." If a plate shows too much growth to isolate a single colony, streak a new plate for isolation following the procedure above.

Generally, bacteria are grown on plates in order to identify colonies that have an antibiotic resistance gene. The plates used by iGEM have an antibiotic in the media so that only these colonies can grow on them. Use of such plates allows screening for colonies that have the desired genes. However, this method of screening for colonies is not completely reliable. For example, the common antibiotic ampicillin does not kill non-resistant cells; it merely prevents the bacteria from multiplying. Cells with ampicillin resistance produce an enzyme that breaks down ampicillin in the media. This provides non-resistant cells the opportunity to grow in the antibiotic-free area that develops around a resistant colony on solid media. These non-resistant colonies are called *satellite colonies* and are generally smaller than the resistant colony. When a broth culture is inoculated with satellite colonies, the culture will not grow overnight because the cells are non-resistant and the liquid media should contain antibiotic.

### Inoculation

(per 5 mL broth culture inoculated)

1. Appropriately label each tube with white tape before inoculation.
2. Remove the cap from the LB tube, flame mouth of tube, and add antibiotic (see Appendix D for amount). Flame tube again and replace cap.
3. Flame the loop you will be using for inoculation and allow the loop to cool.
4. Touch the loop to a single colony on an agar plate.
5. Remove the cap from the LB tube, flame mouth of tube, and tilt the tube so that the loop can access the media without inserting the unsterilized handle of the loop into the tube.
6. Swish the loop in the media.
7. Remove the loop from the tube without letting the loop touch the sides of the tube.
8. Immediately flame and recap the tube and place it in a rack.
9. Flame the loop again.

**Note:** When inoculating from an older culture, it is important to remember that over time (within 1 or 2 days) the antibiotic in the liquid culture will degrade. Older cultures may have contaminating growth, and/or the previously resistant microbes may have "lost" the resistant plasmid that you are trying to amplify. Therefore, it is best to inoculate from cultures within the first 24 hours of growth.

### **Concentration Calculations**

In the iGEM lab, there are several reagents that are prepared in a concentrated stock solution. The designation used to indicate the level of concentration is a number followed by "x." This number indicates how many times more concentrated the solution is than the working concentration (1x). It is imperative to understand the calculations needed to dilute stock solutions. A simple equation can be used to calculate the amount of stock solution that should be added to the media to reach the final concentration and volume:

$$C_1 * V_1 = C_2 * V_2$$

where

$C_1$  = the starting concentration of the stock solution

$V_1$  = the volume of stock solution needed for dilution

$C_2$  = the final concentration following dilution

$V_2$  = the final volume of the dilution

For example, when inoculating a 5 mL broth culture ( $V_2$ ) with a 1000x antibiotic stock solution ( $C_1$ ), a final concentration of 1x ( $C_2$ ) is needed. The only unknown variable is the volume of the stock solution that is needed. Therefore, the value of  $V_1$  needs to be determined. Rearrange the above equation to solve for  $V_1$  and insert the values in the appropriate variables:

$$V_1 = (C_2 * V_2) / (C_1) = (1x * 5 \text{ mL}) / (1000x) = 0.005 \text{ mL} = 5 \mu\text{L}$$

This calculation states that 5  $\mu\text{L}$  of the stock solution needs to be diluted into 5 mL of liquid culture to obtain a 1x solution.

## Background Information

### DNA (Deoxyribonucleic acid)

DNA contains the genetic instructions used in the development and function of all known living organisms. The information in DNA is stored as a code made up of four chemical bases: adenine (A), guanine (G), cytosine (C), and thymine (T). The order, or sequence, of these bases determines the information available for building and maintaining an organism, similar to the way in which letters of the alphabet appear in a certain order to form words and sentences. DNA bases pair up with each other, A with T and C with G, to form complementary units called *base pairs*. These base pairs are connected by *hydrogen bonds*, shown in Figure 1 as dotted lines. Adenine and thymine form two hydrogen bonds, while guanine and cytosine form three hydrogen bonds. This means that the strength of the interaction between guanine and cytosine is greater than that between adenine and thymine.

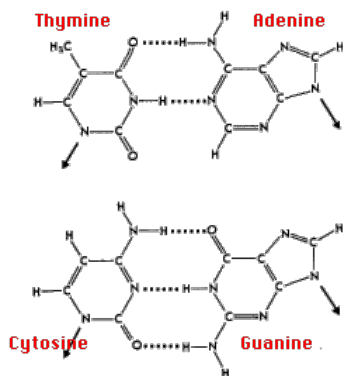
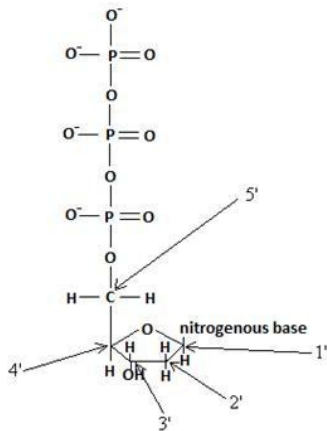


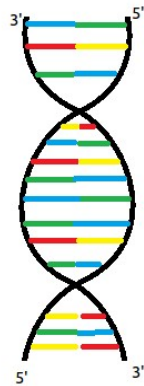
Figure 1 – DNA base pairing

Each base is attached to a sugar molecule, which is attached to a phosphate molecule. Together, a base, sugar, and phosphate are called a *nucleotide* (Figure 2). Nucleotides are found in a few different forms in cells, including different forms for DNA and for RNA (see RNA section below). The nucleotides that form DNA molecules, sometimes called deoxynucleotides, contain a sugar called deoxyribose. Different forms of nucleotides can differ in the number of phosphate groups attached to the sugar (one, two, or three). Deoxynucleotides are abbreviated as dNTP, dNDP, and dNMP, where the "d" stands for "deoxy"; the "N" stands for "nucleotide"; the "T," "D," or "M" stands for the number of phosphate groups ("tri," "di," or "mono," respectively); and the "P" stands for "phosphate." The "N" can be replaced with one of the letters representing a specific base (A, T, G, or C) when referring to a specific nucleotide (e.g., dGTP for deoxyguanosine triphosphate).



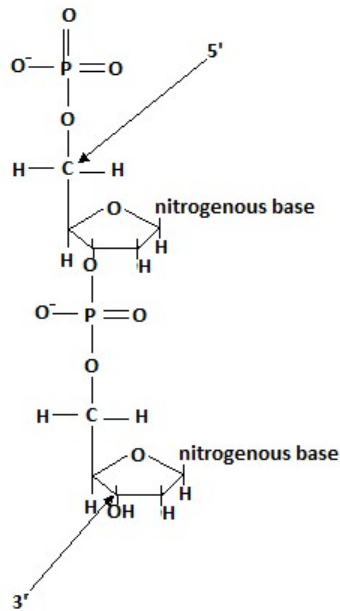
**Figure 2** – A deoxynucleotide triphosphate (dNTP)

In DNA, dNMPs are covalently bonded in two long strands that form a spiral called a *double helix* (Figure 3). The structure of the double helix is somewhat like a ladder, with the base pairs and their hydrogen bonds forming the ladder's rungs and the sugar and phosphate molecules forming the vertical sidepieces of the ladder. The two strands run in opposite directions, and are said to be *antiparallel*. These strands are held together only by the hydrogen bonds between the complementary base pairs. The strength of the double helix is dictated by the density of hydrogen bonds, and thus the composition of the base pairs; since G and C have a stronger interaction, double-stranded DNA with a higher GC content will be harder to break apart.



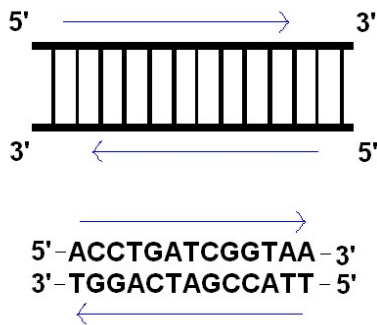
**Figure 3** –A DNA double helix showing base pairing

Each carbon in the sugar of a nucleotide has a numeric designation between 1' (read "one prime") and 5'. The phosphate group attached to the 5' carbon is referred to as the 5' phosphate, and the hydroxyl group attached to the 3' carbon is referred to as the 3' hydroxyl. When two nucleotides bind together, the 5' phosphate group of the second nucleotide attaches to the 3' hydroxyl of the first nucleotide. The resulting bond is called a *phosphodiester bond* or *phosphodiester linkage*. DNA is always synthesized in the 5'→3' (also written as 5' to 3') direction. Regardless of the length of a sequence of nucleotides, a linear DNA sequence will always start with a nucleotide possessing an unbound 5' phosphate group and end with an unbound 3' hydroxyl group (Figure 4).



**Figure 4** – 5'→3' orientation of nucleotides in DNA

This directionality of the DNA backbone offers a consistent way to orient sequences. The 5' end of the DNA molecule is "up-stream" of the 3' end. This gives the convention of writing DNA sequences starting with the 5' end and ending with the 3' end. This designation of 5'→3' is important in distinguishing between the two strands of the DNA molecule; one strand is said to be in the 5'→3' direction, while the other strand is said to be in the 3'→5' direction (Figure 5).



**Figure 5** – Antiparallel strands of DNA showing 5'→3' and 3'→5' directionality

In Figure 4, nucleotide A is the 5' end of the DNA molecule, and nucleotide B is the 3' end of the molecule. When writing a sequence of any kind, the 5' and 3' symbols are used to indicate the orientation of the nucleotides. For instance, instead of writing AGCTTAC alone, one would write 5'-AGCTTAC-3' to specify the orientation of the sequence.

DNA stores all the information a cell needs to function, but DNA is only a blueprint that the cell must interpret to construct the molecules necessary for life. The main processes involved in this interpretation are known as *transcription* and *translation* (see sections below).

### RNA (ribonucleic acid)

RNA, like DNA, is composed of nucleotides and has a 5'→3' directionality. However, instead of deoxyribose, the nucleotides that form RNA molecules contain a sugar called ribose. Ribose has the same structure as deoxyribose except for an additional hydroxyl group on the 2' carbon. RNA nucleotides are abbreviated as NTP, NDP, and NMP. RNA uses the same bases and base pairing as DNA, except uracil is used instead of thymine. Unlike DNA, RNA is usually single-stranded.

There are a few different types of RNA in cells, such as *messenger RNA (mRNA)*, *transfer RNA (tRNA)*, and *ribosomal RNA (rRNA)*. Each type of RNA serves important functions in the cell, but we will focus primarily on mRNA, which is RNA that codes for proteins in the cell.

### Transcription

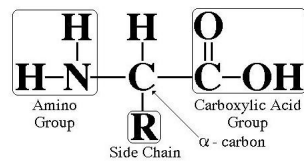
Transcription is the synthesis of RNA from the DNA template. Transcription begins when a protein called RNA polymerase recognizes a specific base sequence in the DNA called a *promoter* and binds to the DNA. The promoter indicates the start of a gene. RNA polymerase



unwinds the two strands of DNA and assembles RNA nucleotides that are complementary to the DNA strand being copied. A *termination sequence* in the DNA indicates where transcription will stop. The RNA produced by transcription is referred to as a *transcript*.

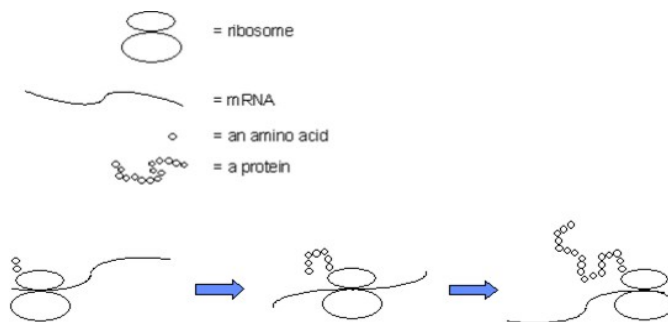
## Translation

Translation is the process by which ribosomes synthesize proteins using the mRNA produced during transcription. A ribosome attaches to the mRNA at a *ribosome binding site (RBS)* near the 5' end of the mRNA molecule. Transfer RNA (an RNA molecule that is bound to a specific amino acid) then transports the appropriate *amino acids* to the ribosome, according to the sequence of *codons* (groups of three nucleotides) on the mRNA molecule. Each amino acid contains an amine group, a carboxyl group, and a side chain specific to that amino acid (Figure 6).



**Figure 6** – Amino acid structure

The ribosome detaches each amino acid from its tRNA and links the amino acids together, forming a *polypeptide*. The bond between the amino group of one amino acid and the carboxyl group of another amino acid is called a *peptide bond*. Just as in DNA synthesis, protein synthesis has directionality: proteins are synthesized from the amino (N) to carboxyl (C) terminus. The chemical properties of the amino acids in the polypeptide cause it to fold into a functional *protein*. Figure 7 is a diagram of translation.



**Figure 7** – Translation

## Molecular Cloning

Molecular cloning is the process by which recombinant DNA molecules are created. Recombinant DNA molecules are DNA sequences that are intentionally assembled through genetic manipulation, and they usually contain DNA from multiple source organisms. Creating useful recombinant DNA is the main focus of the iGEM competition. Molecular cloning is done using a set of molecular genetics techniques that are briefly discussed in this section and described in more detail in the "iGEM Protocols and Reactions" section.

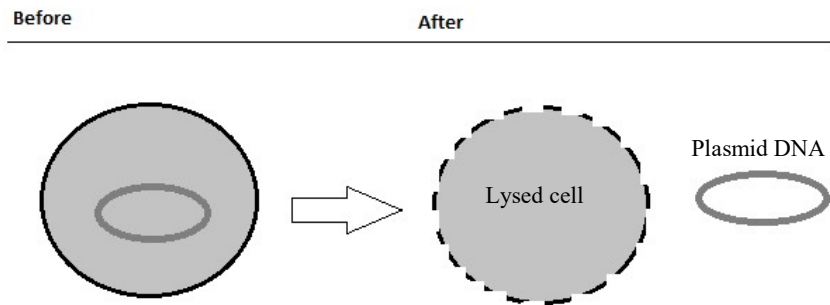
Most of the manipulations of genetic material done in molecular cloning involve *plasmids* (also known as *vectors*). Plasmid DNA can replicate independently of chromosomal DNA in a cell. It is a naturally occurring, double-stranded, circular form of DNA that bacteria use to exchange genes. In the iGEM lab, plasmid DNA is the most common form of genetic material that you will work with, but iGEM labwork is not limited to plasmid DNA.

The plasmid DNA in microbes can be removed from the cells using a process known as plasmid DNA purification (or plasmid preparation). Our lab uses a type of plasmid purification called a *miniprep*. In this process, the cells are *lysed* and their contents are released into solution (Figure 8). The plasmid DNA is then purified from the rest of the cells' components via a series of separations.

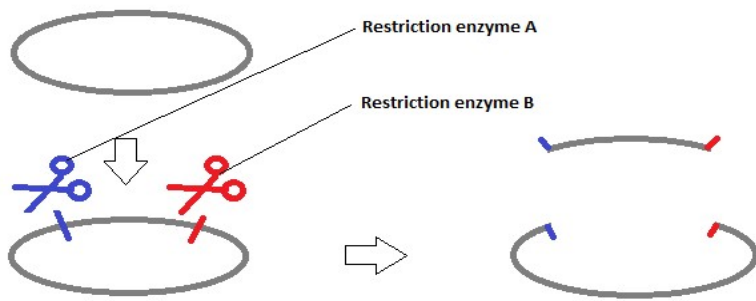
Once purified, sections of the plasmid DNA can be *cut and pasted*. DNA is cut with a special enzyme known as a *restriction enzyme* (or, more scientifically, endonucleases), which can be thought of as "molecular scissors." The reaction is known as a *restriction digest* (or simply a digest). Figure 9 is a simplified diagram of this process.

After the DNA has been cut it can be pasted back together in new combinations. This pasting is known as *ligation* and is shown in Figure 10. The enzyme *DNA ligase* is responsible for joining the DNA fragments.

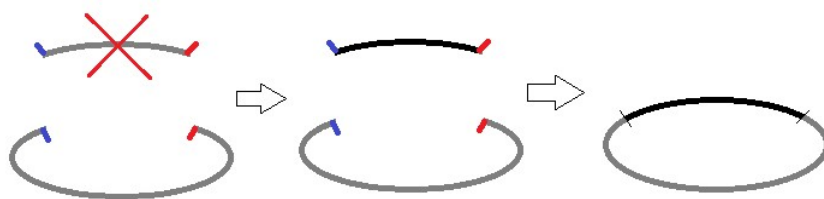
Once the new combinations of DNA have been created, the genetic material can be put into new cells. The procedure used for this is called *transformation*. This process requires *competent cells*, which are able to take up DNA from their environment. Some cells are naturally competent, while others must be treated to induce competence. When bacteria are transformed with plasmid DNA, the cellular machinery makes more copies of the plasmid as the cells multiply. This new DNA can alter the bacteria's behavior or function.



**Figure 8 – Plasmid DNA purification (aka plasmid preparation)**



**Figure 9 – Digestion**



**Figure 10 – Ligation**

## Standard Assembly

One of the goals of the iGEM Foundation is to build a registry of standard biological parts called *BioBricks*. BioBricks are a specific type of recombinant DNA and are said to be standardized because they are made with specific flanking DNA sequences called a *prefix* and a *suffix*. These sequences make it easy to cut and paste BioBricks using a standardized molecular cloning method called *standard assembly*. The prefix contains the EcoRI and XbaI restriction sites. The suffix contains the SpeI and PstI restriction sites.

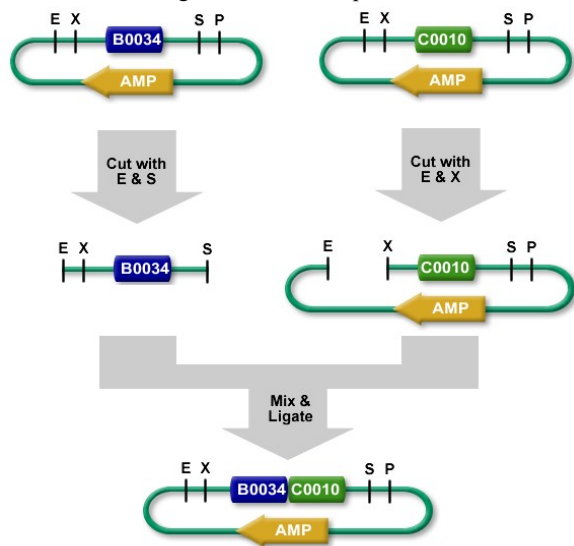
In order to understand why these restriction sites were chosen for standard assembly, the sequence of the restriction sites must be known. Table 6 shows these sequences and the orientation of the cut made by the restriction enzymes in these sites. As you can see from the table, the sticky ends left by XbaI are complementary to the sticky ends left by SpeI, which allows them to anneal and be ligated together. The two sticky ends from a single restriction site will form a functional restriction site when ligated. However, when the sticky ends from the XbaI and SpeI sites are ligated together, the resulting DNA sequence (sometimes referred to as a scar) is a hybrid of the two original restriction sites and is no longer able to be recognized by either restriction enzyme. These properties of these restriction sites are important to standard assembly because they allow for conservation of the proper prefix and suffix through multiple cycles of BioBrick assembly without introducing additional restriction sites.

**Table 6 – Standard Assembly Restriction Sites**

Restriction Enzyme	Recognition Site	Cutting Pattern	Resulting DNA Fragments
EcoRI	5'-GAATTC-3' 3'-CTTAAG-5'	$\begin{array}{c} \downarrow \\ 5'-GAATTC-3' \\ 3'-CTTAAG-5' \\ \uparrow \end{array}$	$\begin{array}{cc} 5'-G & AATTC-3' \\ 3'-CTTAA & G-5' \end{array}$
XbaI	5'-TCTAGA-3' 3'-AGATCT-5'	$\begin{array}{c} \downarrow \\ 5'-TCTAGA-3' \\ 3'-AGATCT-5' \\ \uparrow \end{array}$	$\begin{array}{cc} 5'-T & CTAGA-3' \\ 3'-AGATC & T-5' \end{array}$
SpeI	5'-ACTAGT-3' 3'-TGATCA-5'	$\begin{array}{c} \downarrow \\ 5'-ACTAGT-3' \\ 3'-TGATCA-5' \\ \uparrow \end{array}$	$\begin{array}{cc} 5'-A & CTAGT-3' \\ 3'-TGATC & A-5' \end{array}$
PstI	5'-CTGCAG-3' 3'-GACGTC-5'	$\begin{array}{c} \downarrow \\ 5'-CTGCAG-3' \\ 3'-GACGTC-5' \\ \uparrow \end{array}$	$\begin{array}{cc} 5'-CTGCA & G-3' \\ 3'-G & ACGTC-5' \end{array}$

Figure 11 shows an example of the use of the standard assembly method to combine a blue BioBrick and a green BioBrick into a blue-green system. For this assembly, the blue part is cut out of its plasmid with EcoRI and SpeI. The resulting fragment is called the insert because it

will be inserted into the plasmid containing the green part. In a separate reaction, the plasmid containing the green part is cut open using EcoRI and XbaI. Using gel electrophoresis and gel extraction, the insert for the blue part and the vector containing the green part are isolated and purified, and the unwanted fragments are discarded. The insert and vector are then ligated together. The EcoRI sticky ends will anneal, and the SpeI and XbaI sticky ends will anneal. When the DNA backbone is ligated, the resulting plasmid contains the blue-green system, as shown at the bottom of Figure 11. This new plasmid can then be transformed into cells.



**Figure 11** – Standard Assembly. The letters E, X, S, and P represent the restriction sites EcoRI, XbaI, SpeI, and PstI, respectively.

The host cell into which the recombinant DNA containing BioBricks is inserted is referred to as a chassis. Synthetic biology uses standard chassis to help control experimental factors inherent in complex biological systems. This increases consistency of the experimental conditions among labs, which aids in the ability of labs to produce replicable results. There are several standardized chassis used in synthetic biology and iGEM, including different species of prokaryotic and eukaryotic cells. Many iGEM projects use a specific strain of *E. coli* called DH5 $\alpha$ .

## iGEM Protocols and Reactions

The following sections explain the theory and procedures for reactions commonly performed in the iGEM lab. The iGEM Foundation has official protocols for all of these commonly used procedures, which can be found at [partsregistry.org](http://partsregistry.org). Due to differences in equipment, materials, and budget, our iGEM team's protocols sometimes differ from the iGEM standard. All of these protocols are used for the common laboratory strain of *E. coli*, H5 $\alpha$ . of the work performed in the iGEM lab uses this chassis.

### Miniprep

A miniprep is a type of plasmid DNA purification which is usually performed using a commercial kit with reagents specifically for this procedure. The DNA is extracted from whole cells in liquid culture. The yield of this process is usually less than 20  $\mu\text{g}$  of purified plasmid DNA from a 5 mL liquid culture. Cells that have been transformed with the plasmid of interest are lysed to release their contents. A series of purification steps isolate the plasmid DNA from the rest of the cellular contents and debris (membranes, RNA, protein, chromosomal DNA, etc). It is necessary to isolate the plasmid DNA from the cells in order to make the desired alterations to the DNA. The steps involved in a miniprep and the concepts that underlie them are described below. The iGEM lab uses the High-Speed Plasmid Mini Kit from IBI Scientific, and the following information may be specific to the reagents in that kit.

- **Cell Growth and Harvesting:** The miniprep procedure starts with the growth of the bacterial cell culture harboring the plasmid of interest. As the cells multiply, they will make many copies of the plasmid. When sufficient growth has been achieved (for *E. coli* this is typically overnight), the cells are pelleted by centrifugation to remove them from the growth medium.
- **Resuspension:** The pellet is then resuspended in a resuspension buffer (labeled PD1 in our kit), resulting in a more concentrated suspension of the cells than the initial culture. This solution is a buffer containing EDTA, which protects the DNA from being degraded throughout the procedure. It also contains ribonuclease (RNase), which degrades RNA that would contaminate the plasmid DNA.
- **Lysis:** The second solution added in a miniprep is the lysis buffer (PD2), which contains sodium hydroxide (NaOH) and the detergent SDS. SDS and NaOH solubilize the cell membranes, break down cell walls, and denature most of the cells' proteins. Breaking down the cell walls and membranes releases the cell contents into solution, and denaturing the proteins helps separate the proteins from the plasmid later in the process. Shaking the tube is required in this step to aid the functions of the chemicals by thorough mixing.

- **Neutralization:** If the cell lysis step continues too long, it will begin to damage the DNA; therefore, the reaction must be neutralized at the appropriate time. Addition of the neutralization solution (PD3, which contains potassium acetate) lowers the alkaline pH of the mixture. Neutralizing the pH not only stops lysis, but it is necessary for the rest of the plasmid purification steps. While the plasmid dissolves easily in solution, the genomic DNA, denatured cellular proteins, and all other cell debris stick together to form a white precipitate. The precipitate can easily be separated from the plasmid DNA solution by centrifugation.
- **Binding and washing:** After spinning down the precipitate, the supernatant contains primarily plasmid DNA with a few impurities. The supernatant is transferred to a glass-fiber filter-column provided by the kit (the PD Column), which is nested in a collection tube and spun in the microcentrifuge. During centrifugation, the plasmid DNA binds to the filter while most of the impurities remain in the flow-through. After binding, a series of wash steps (W1 Buffer then Wash Buffer with ethanol) removes any remaining impurities from the plasmid DNA and filter. These washes involve centrifugation, and the wash buffers are discarded.
- **Drying and elution:** Once the impurities have been removed, the filter is dried by centrifugation (without the addition of a buffer solution). This process removes excess wash buffer from the filter. The dried filter column is then transferred to a new (appropriately labeled) 1.5 mL Epi tube. The plasmid DNA is removed from the filter by adding a solution (Elution Buffer) to dissociate the plasmid DNA from the filter. The elution buffer is given time to absorb into the filter before centrifugation. After centrifuging, the filter column can be discarded because the plasmid DNA is stored in the flow-through in the 1.5 mL Epi tube.
- **Measuring DNA concentration:** While this is not part of the miniprep protocol, measuring the concentration and purity of extracted plasmid DNA is necessary before using the DNA in other reactions. DNA concentration and purity are measured using a NanoDrop, which is a special type of spectrophotometer used in molecular biology. Different cellular components (nucleic acids, proteins, salts, etc.) absorb specific wavelengths of light. When measuring DNA concentration, the main contaminants that can affect later reactions are salts and proteins. The NanoDrop measures absorbance at the specific wavelengths for nucleic acids (260 nm), salts (230 nm), and proteins (280 nm) and reports their concentrations. The NanoDrop will output a graph of absorbance and three values of interest: concentration of DNA in ng/ $\mu$ L, ratio of DNA absorbance to salt absorbance (shown as the 260 nm / 230 nm ratio), and ratio of DNA absorbance to protein absorbance (shown as the 260 nm / 280 nm ratio). Record these three values in the lab notebook whenever you complete a miniprep and NanoDrop measurement. For DNA, there should be a strong peak in the graph at 260 nm. The 260 nm / 280 nm ratio should be between 1.8 and 2.0. The 260 nm / 230 nm ratio should be over 2.0.

### Kit Miniprep Protocol

The iGEM lab uses the following miniprep protocol for high-purity purification. It is slightly modified from the High-Speed Plasmid Mini Kit protocol from IBI Scientific. All of the materials in this protocol are included in the kit except Epi tubes. Gloves are highly recommended for this procedure due to acid/base and irritant hazards.

1. Transfer 1.5 mL of liquid bacterial culture to a 1.5 mL Epi tube.
2. Centrifuge at 14-16,000 x g (max speed on the iGEM microcentrifuge) for 1 minute and discard supernatant into a container labeled "used solutions."
3. Repeat steps 1 and 2 until there is no more culture left in the culture tube.
4. Add 200  $\mu$ L of PD1 Buffer to the Epi tube and resuspend the cells by gently pipetting up and down until there are no visible chunks. The PD1 Buffer is kept in the G6A refrigerator door.
5. Add 200  $\mu$ L of PD2 Buffer and shake tube vigorously for approximately 30 seconds. The kit protocol says to "gently invert 10 times" but this does not thoroughly mix the increasingly viscous solution. The solution will become snotty-looking. Do NOT vortex (this may cause the genomic DNA to shear).
6. Let stand at room temperature for 2 minutes to ensure the lysate is homologous.
7. Add 300  $\mu$ L of PD3 Buffer and mix immediately by inverting the tube 10 times. DO NOT VORTEX. The solution will become snowy-looking.
8. Centrifuge at 14-16,000 x g (max speed) for 10 minutes.
9. Place a PD Column in a 2 mL Collection Tube. Pour the supernatant produced in step 8 into the PD Column, being careful to avoid adding any precipitate. The precipitate can clog the filter or contaminate the plasmid DNA you are trying to purify.
10. Centrifuge at 14-16,000 x g (max speed) for 30 seconds. Discard the flow-through and place the PD Column back in the 2 mL Collection Tube.
11. Add 400  $\mu$ L of W1 Buffer to the PD Column.
12. Centrifuge at 14-16,000 x g (max speed) for 30 seconds. Discard the flow-through and place the PD Column back in the 2 mL Collection Tube.
13. Add 600  $\mu$ L of Wash Buffer to the PD Column.
14. Centrifuge at 14-16,000 x g (max speed) for 30 seconds. Discard the flow-through and place the PD Column back in the 2 mL Collection Tube.
15. Centrifuge at 14-16,000 x g (max speed) for 10 minutes to dry the PD Column.
16. Label a 1.5 mL Epi tube and transfer the dried PD Column to this tube. Add 50  $\mu$ L of sterile MilliQ water or Elution Buffer directly to the center of the PD Column filter without touching the pipette tip to the filter. Make sure the water absorbs fully into the filter and does not adhere to the side of the column.
17. Let stand for at least 2 minutes.
18. Centrifuge at 14-16,000 x g (max speed) for 2 minutes to elute the DNA. Discard the PD Column and store the 1.5 mL Epi containing the plasmid DNA in the iGEM freezer.



**Notes:**

- If the PD2 Buffer has developed precipitates, warm the buffer to 37°C and gently shake to dissolve.
- PD3 Buffer and W1 Buffer contain guanidine hydrochloride which is a harmful irritant. Individuals performing this procedure should wear gloves.
- If you are concerned that the concentration of purified DNA will be low, replace steps 16-18 with the following steps: Add 30 µL MilliQ water to the center of the column, incubate at room temperature for 5 minutes, then centrifuge for 1 minute at max speed. Add 20 µL MilliQ water, incubate for 1 minute on the bench, then centrifuge for 1 minute at max speed. This procedure can increase the concentration of DNA in the final sample.

**Kitless Miniprep Protocol**

The iGEM lab uses the following miniprep protocol for high-yield purification. All of the materials in this protocol are stored in the G6A fridge. Gloves are highly recommended for this procedure due to acid/base hazards.

1. Transfer 1.5 mL of liquid bacterial culture to a 1.5 mL Epi tube.
2. Centrifuge at 14-16,000 x g (max speed on the iGEM microcentrifuge) for 1 minute and discard supernatant into a container labeled "used solutions."
3. Repeat steps 1 and 2 until there is no more culture left in the culture tube.
4. Add 200 µL of Solution 1 (50 mM Tris-HCl, 10 mM EDTA, 100 µg/mL RNase A, pH 8.0) to the Epi tube and resuspend the cells by gently pipetting up and down until there are no visible chunks.
5. Add 200 µL of Solution 2 (1% SDS, 0.2 M NaOH) and shake tube vigorously for approximately 30 seconds. The solution will become snotty-looking. Do NOT vortex (this may cause the genomic DNA to shear).
7. Add 200 µL of Solution 3 (3.0 M Potassium Acetate buffer, pH 5.2) and mix immediately by inverting repeatedly. DO NOT VORTEX. The solution will become snowy-looking.
8. Centrifuge at 14-16,000 x g (max speed) for 5 minutes.
9. Transfer the supernatant into a clean, labeled Epi tube, being careful to avoid the precipitate. Discard the tubes with the precipitate.
10. Add 600 µL of 91% isopropanol and shake tube vigorously to mix.
11. Let tubes stand for 2 minutes at room temperature.
12. Centrifuge at 14-16,000 x g (max speed) for 5 minutes.
13. Discard the supernatant and add 200 µL of ice-cold 70% ethanol and shake tube vigorously to mix.
14. Centrifuge at 14-16,000 x g (max speed) for 3 minutes.
15. Carefully discard supernatant, use a pipette to remove as much liquid as possible. Let tubes sit in a fume hood, open and on their sides until then ethanol has evaporated (10-20 minutes).

16. When the ethanol has evaporated, add 50  $\mu$ L of TE buffer to the tube and pipette up and down, along the walls of the tube to ensure all the DNA has been in contact with the TE buffer.
17. Make sure the tube is appropriately labeled and store in the iGEM freezer.

**Notes:**

- After removing Solution 2 from the fridge, it will contain a white precipitate. This precipitate must be completely dissolved before using Solution 2. This may be done by gently heating the solution in a waterbath.
- If there is still white precipitate floating in the tube after step 8, centrifuge again for 5 minutes. If the precipitate is still floating, it can often be removed with a large pipette tip. The precipitate often sticks to the sides of the pipette tip, allowing for easy removal.

## Restriction Digest

Restriction digests utilize a special type of enzyme known as a *restriction enzyme* (also called a restriction endonuclease). These enzymes "cut" double stranded DNA (by breaking the *phosphodiester bonds*) at a specific sequence of nucleotides (known as the *restriction site*). Many restriction enzymes cleave DNA in such a manner that they result in *sticky ends*. Sticky ends are short single-stranded overhangs at the end of a digested double-stranded segment of DNA (Figure 12). Other restriction enzymes cut such that they leave *blunt ends*, or ends with no single-stranded portions hanging off (Figure 12). The restriction enzymes that are most commonly used in the iGEM lab are EcoRI, XbaI, SpeI, and PstI, which are detailed in the Standard Assembly section.

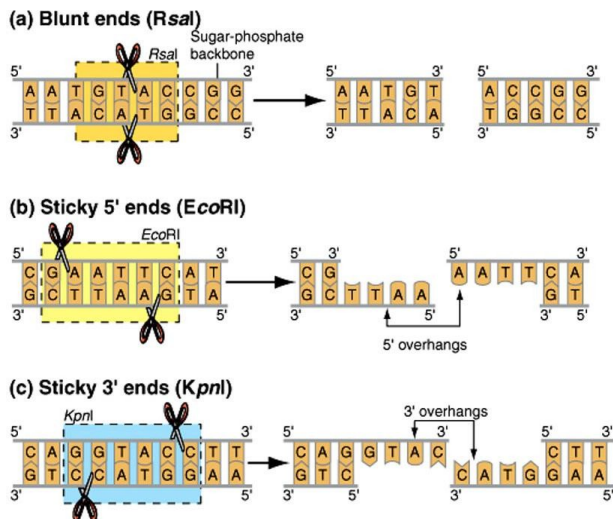


Figure 12 – Types of cuts made by a restriction digest

Restriction digests can be performed using either a single restriction enzyme or multiple restriction enzymes. In the iGEM lab, double digestions (using two restriction enzymes) are most common. Besides the restriction enzymes, a digestion reaction requires DNA (to be cut) and a buffer to facilitate enzymatic activity. Sometimes BSA (bovine serum albumin) is also added to restriction digestions to reduce non-specific action. Water is also added to bring the reaction to the desired volume.

The volume of DNA required for a digest will depend on the concentration of miniprep DNA (as calculated by the NanoDrop). Each digestion reaction tube should contain approximately 1000 ng of DNA. Before each digestion, you will need to calculate the volume of DNA required for the reaction. For example, if the DNA concentration is 160 ng/ $\mu$ L, to have 1000 ng in the reaction mixture, you will need to add 6.25  $\mu$ L of DNA to the digest tube.

The total volume for a digest in the iGEM lab should always be 25  $\mu$ L. The volume of 10x buffer will always be 2.5  $\mu$ L in a 25  $\mu$ L digest. The volume of each enzyme used in the iGEM lab is 1  $\mu$ L per reaction, which contains more enzyme than is required for the reaction. Since the DNA volume is variable (depending on the concentration of DNA), you will have to add varying amounts of MilliQ water in order to obtain the correct final reaction volume. The total volume of water and DNA for a double digest should be 20.5  $\mu$ L (or 21.5  $\mu$ L for a single digest).

After adding the reaction components, the digest is incubated at 37°C, which is optimum for enzymatic activity. The enzymes in the mixture are then deactivated in a "heat-kill" step at 80°C. The digested DNA can then be used immediately (e.g., in a ligation reaction) or stored in the iGEM freezer.

#### Restriction Digest Protocol

The following is the recipe for the digestion reaction mixture. This recipe specifies the amount of each reagent required per sample to be digested. Be sure to select a buffer that is compatible with the restriction enzyme(s) you are using. For double digestions, the iGEM lab generally uses Tango buffer, which contains BSA. Calculate the required volumes of DNA and water first, then add the reaction components. Adding enzyme(s) before other components (especially the buffer) could result in reduced enzymatic activity. It is EXTREMELY important to keep the enzymes on ice or in a freezer box at ALL times and to have them out of the freezer as little as possible. The enzymes are very expensive and sensitive to temperature changes.

Double Digestion:

Sterile MilliQ	calculated for final volume of 25 $\mu$ L
10x Buffer	2.5 $\mu$ L
DNA	up to 3000 ng
Enzyme 1	1 $\mu$ L
Enzyme 2	1 $\mu$ L

Single Digest:

Sterile MilliQ	calculated for final volume of 25 $\mu$ L
10x Buffer	2.5 $\mu$ L
DNA	up to 3000 ng
Enzyme	1 $\mu$ L

1. Calculate the amount of each reagent required based on the concentration of DNA and the number of reactions to be performed.
2. Add the reagents to a sterile 0.2 mL PCR tube in the order specified above. Don't forget to keep enzymes on ice! Buffer may be frozen when removed from the freezer, and it must be completely thawed before use to ensure uniform concentration.
3. Mix by flicking the tube, and then spin the reaction down for a few seconds in the mini centrifuge to make sure all the reagents are mixed in the bottom of the tube.
4. Run the reaction in the thermocycler using the "igem\_digest" program.
5. The digests can be used immediately or stored in the iGEM freezer.

**Notes:**

- When running a large number of digests, it may be advisable to pre-mix a "master mix." A master mix contains all the digest reagents (except the DNA) needed for all the digests to be performed. To use this method, mix enough MilliQ, buffer, and enzyme (not DNA) in a single 1.5 mL Epi tube for the number of reactions you plan to perform. Next, aliquot the appropriate amount of the master mix into each reaction tube and add the DNA to the individual tubes. You must make a separate master mix for each different concentration of DNA because the amount of water added to the master mix will vary depending on the DNA concentration.
- Be aware that incubating for more than an hour could result in "star" activity. Star activity is when the restriction enzyme cuts at a sequence other than its restriction site.

## Ligation

Joining linear DNA fragments together with covalent bonds is called ligation. More specifically, DNA ligation involves creating a phosphodiester bond between the 3' hydroxyl of one nucleotide and the 5' phosphate of another. In the iGEM lab, the purpose of ligation is to add a smaller piece of DNA called an insert into a plasmid, or vector. The enzyme used to ligate DNA fragments is T4 DNA ligase, which originates from the T4 bacteriophage. This enzyme ligates DNA fragments that have overhanging, cohesive ends (sticky ends) that are annealed together, as shown in Figure 12. T4 DNA ligase will also ligate fragments with blunt ends (also shown in Figure 12), although higher concentrations of the enzyme are usually recommended for blunt-end ligation.

Ligation occurs in two basic steps. It starts with the collision and annealing (via hydrogen bonding between complementary nucleotides) of sticky ends. The two strands can also join with blunt ends, but since there are no overhanging single-stranded sticky ends, the strands do not stick together and ligation is less efficient. The kinetics of the collision of sticky ends and the resultant hydrogen bonds are important to achieve an effective ligation reaction. The hydrogen bonding that holds complementary nucleotides together is stronger at lower incubation temperatures. Therefore, lower temperatures can increase the amount of time the sticky ends remain annealed, which increases the efficiency of the ligation reaction.

The second step in the ligation reaction requires the DNA ligase. The ligase catalyzes the formation of a covalent bond between the 3' hydroxyl of one nucleotide and the 5' phosphate of the adjacent nucleotide. This process requires ATP, which is in the ligase buffer.

The DNA ligase enzyme is most efficient at 25°C, but the optimal temperature for annealing of sticky ends is closer to 1°C. Since these two steps must occur simultaneously throughout the entire ligation reaction, the incubation must be at an intermediate temperature.

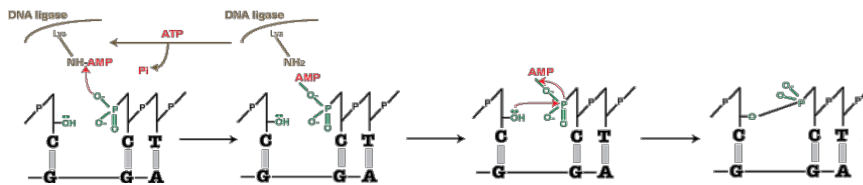


Figure 13 – Ligation mechanism

### Ligation Protocol

1. Mix the following reagents in a 0.2 mL PCR tube in order:

Digested DNA sample 1 (vector)	2 $\mu$ L
Digested DNA sample 2 (insert)	6 $\mu$ L
10x T4 DNA Ligase Buffer	1 $\mu$ L
T4 DNA Ligase	1 $\mu$ L
2. Run the reaction in the thermocycler using the "igem\_lig" program overnight.
3. The ligation product can be used immediately or stored in the iGEM freezer.

### Notes:

- Don't forget to keep enzymes on ice!
- Buffer may be frozen when removed from storage in freezer, and must be completely thawed before use to ensure uniform concentration.
- Vortex the ligation buffer before use to help dissolve any precipitates.
- The ligase buffer should be stored in small aliquots to prevent too much freezing and thawing. If the ligation buffer is thawed too many times, ligation efficiency can decrease.
- When performing a ligation reaction, efficiency can sometimes be increased by using different ratios of insert DNA to vector DNA. The Instructors will determine if a new ligation recipe is necessary.

### Transformation

*Transformation* is the uptake of genetic material by a cell from its surroundings through the cell membrane, which results in genetic alteration of the cell. Transformation occurs naturally in some species of bacteria, but it can also be induced by artificial means. Bacteria that are capable of being transformed, whether naturally or artificially, are called competent. Transformation is one of three processes by which exogenous genetic material may be introduced into a bacterial cell; the other two are *conjugation* (transfer of genetic material between two bacterial cells in direct contact) and *transduction* (injection of foreign DNA by a bacteriophage virus into the host bacterium). Competent cells have cell membranes with increased permeability. This state can be induced for *chemical transformations* (*chemically competent cells*) or for *electroporation* (*electrically competent cells*). In our iGEM lab, chemical transformations are used more commonly than electrical transformations.

### Chemical Transformation

Chemical transformation uses temperature shock to transform chemically competent cells. Although some bacteria are naturally competent, competence is usually induced before performing a chemical transformation in a lab. In the iGEM lab, we chemically treat our normal

**Commented [GKM(1):** I think instead of saying this we should include a section about calculating molarity from ng/uL and then give reasonable molar ratios (1:1, 3:1 etc.). If anything we should be encouraging people to calculate this every time IMO

**Commented [L2R1]:** That's the rigorous way to do it, but much more complicated.

*E. coli* strain ( H5α) to induce competence, although different strains of pre-made competent cells can be purchased from biotechnology companies. The treatment used to induce competence weakens the cell membrane, so competent cells must be handled carefully to minimize cell death. Once competence is induced, competent cells are stored at -80°C to preserve them before use. It is important to keep the cells at the correct temperature during the procedure not only to preserve the fragile cells, but also because temperature shock is the mechanism of transformation.

At the beginning of the chemical transformation, competent cells are "thawed" on ice, and the DNA you wish the cells to uptake is added to the cell solution. After the cells incubate with the DNA on ice, they are heated for a very short time. The heat shock causes small breaches to form in the cell membrane, through which DNA in the media can enter. Immediately following the heat shock, the cells are put back on ice to restabilize the cell membrane. A rich, non-selective media called SOC is then added to the cells, and they are incubated at 37°C. This final incubation is a recovery step that is essential for the cells to reestablish homeostasis and grow. Finally, the cells are plated on solid media containing an antibiotic that selects for successfully transformed cells because the plasmid contains an antibiotic resistance gene. After the transformation procedure is complete, the cells are no longer competent.

#### General Chemical Transformation Protocol

1. Acquire a 1.5 mL Epi tube containing chemically competent cells and thaw on ice.  
Competent cells are pre-made, aliquoted to 20-40 μL, and stored in a -80°C freezer.
2. Add 1-2 μL of purified plasmid DNA to cells, keeping cells on ice as much as possible.  
Mix by gently pipetting up and down.
3. Incubate cells on ice for 30 minutes.
4. Heat-shock the cells by placing them in a 42°C water bath for 60 seconds.
5. Incubate the cells on ice for 5 minutes.
6. Add 200 μL of sterile SOC broth.
7. Tape transformation tube(s) to the shaking platform of the 37°C shaking incubator.  
Incubate the cells for 1-2 hours.
8. While cells are incubating, label two plates per tube and place in incubator to pre-warm the plates.
9. For each transformation, pipette 20 μL of transformed cells on one plate and 200 μL on a separate plate. Spread transformed cells across plate using sterile glass beads.
10. Incubate plates at 37°C in stationary incubator for 12-14 hours (make sure to incubate the plate lid-side down).

#### **Notes:**

- SOC is **extremely** easy to contaminate, so be especially vigilant with aseptic technique, minimize the amount of time the cap is removed, and be careful not to breathe or speak near the uncapped bottle.
- Before using SOC, make sure it is uncontaminated.



- Some antibiotics are harsher on newly transformed cells; use longer recovery times (up to 2 h) for these antibiotics (chloramphenicol and kanamycin in our lab).
- Pre-warming plates is not necessary, but may increase transformation efficiency.

### Electrical Transformation

Electrical transformation, also called electroporation, uses an electrical field to transform electrocompetent cells. Electrocompetent cells are prepared by thoroughly washing them to remove all medium salts, resuspending them in a non-conductive solution, and storing them at  $-80^{\circ}\text{C}$ . It is important to minimize the conductivity of the solution so that arcing does not occur when the electrical field is applied. Arcing is indicated by a popping noise during electroporation, and usually results in mass cell death. In addition to the conductivity of the solution, arcing can be caused by bubbles in the solution, damaged electrodes, or moisture on the electrodes. Even if arcing occurs, the transformation may still be successful, but it will be less efficient.

At the beginning of electrical transformation, the competent cells are "thawed" on ice, and the DNA you wish the cells to uptake is added to the cell solution. The solution is kept cold to reduce heat damage to the cells. The solution is transferred to a cold cuvette, which is a special type of container that has electrodes between which the cell solution is deposited. The cuvette is placed into an instrument called an electroporator. The electroporator generates an electrical field across the cuvette. This electrical field alters the membrane potential of the cells, which induces the formation of nanometer-scale hydrophilic pores in the membrane through which plasmid DNA can enter. The exact mechanism by which the DNA enters the cells is not known; it is hypothesized that the mechanism could be diffusion or analogous to electrophoresis.

Immediately following electroporation, a rich non-selective media called SOC is added to the cells and they are incubated at  $37^{\circ}\text{C}$ . As in chemical transformation, this final incubation is a recovery step that is essential for the cells to reestablish homeostasis and grow. Finally, the cells are plated on solid media that contains an antibiotic that selects for successfully transformed cells because the plasmid contains an antibiotic resistance gene.

#### Electrical Transformation Protocol

1. Pre-chill a clean cuvette in the freezer. Try to choose a cuvette with no cracks or holes.
2. Acquire a 1.5 mL Epi tube containing electrocompetent cells and keep on ice. Competent cells are pre-made and stored in a  $-80^{\circ}\text{C}$  freezer. The cell solution should still be almost frozen when used (not "thawed").
3. Add 1-2  $\mu\text{L}$  of purified plasmid DNA to cells, keeping on ice as much as possible. Mix by gently pipetting up and down.

4. Pipette the cell solution between the electrodes of the cuvette and cap the cuvette. Be very careful not to introduce any bubbles. If necessary, gently tap the cuvette on the lab bench to evenly distribute the cell solution.
5. Turn on the electroporator and make sure it is set to 1800 V.
6. Wipe the cuvette dry with a Kim-wipe.
7. Open the lid of the electroporator, insert the cuvette, and close the lid. **Do not force the cuvette into the slot.** The cuvette has a knob that fits into the notch of the electroporator slot.
8. Hold the pulse button and release when the machine beeps (or when you hear a popping noise due to arcing). If arcing occurs, there is a reduced chance that the transformation was successful. Make note of the pop in the lab notebook and continue to the next step.
9. Remove the cuvette, close the lid, and turn off the machine. Immediately proceed to step 10.
10. Add 1 mL of sterile SOC broth to the cuvette and mix by gently pipetting up and down.
11. Transfer the cell solution to a labeled 1.5 mL Epi tube.
12. Tape the transformation tube to the shaking platform of the 37°C shaking incubator. Incubate the cells for 45 minutes.
13. While cells are incubating, label two plates per tube and place in incubator to pre-warm the plates.
14. Pipette 20  $\mu\text{L}$  of transformed cells onto one plate and 200  $\mu\text{L}$  onto another plate. Spread transformed cells across the plates using sterile glass beads.
15. Incubate plates lid-side down at 37°C in stationary incubator for 12-14 hours.
16. Rinse the cuvette with ethanol and dry.

**Notes:**

- Cuvettes should have no cracks or holes in them. Put cuvettes that have holes or cracks on the iGEM bookshelf with a note indicating that they are broken. If no intact cuvettes are available, choose a cuvette that looks the least damaged.
- The 2  $\mu\text{L}$  DNA limit is there to limit the amount of salts in the cuvette. If arcing is a continual issue, using less than 2  $\mu\text{L}$  of DNA may alleviate this issue.
- Pre-warming plates is not necessary, but may increase transformation efficiency.

## Gel Electrophoresis

Gel electrophoresis is used in the iGEM lab to separate different segments of DNA based on their size. The iGEM lab uses 1% agarose gels containing ethidium bromide for electrophoresis. These gels are cast in a plastic tray, and a comb is inserted before the gel cools. After cooling, the comb is removed, leaving wells in the gel in which the DNA is loaded. The gel is submerged in a gel box filled with TAE buffer, and the gel is run horizontally (some gels are run vertically).

DNA is negatively charged and is moved through a gel by an electric current. The agarose gel forms a matrix through which the DNA must navigate. Thus, smaller fragments of DNA move through the gel faster than large fragments of DNA. A DNA ladder is used as a reference to determine the size of the DNA fragments in a sample. A ladder is composed of several DNA fragments of known sizes.

Before DNA is run on a gel, it must be mixed with loading dye. The loading dye contains glycerol and two different dyes. When mixed with the DNA sample, the glycerol increases the density of the sample and prevents the DNA from escaping from the well. The two dyes form the only visual bands while the gel is running, allowing for a visual check of the distance the DNA has traveled.

The ethidium bromide in the gel is a fluorescent dye that intercalates between the bases of the DNA helix. After the gel is run, it is visualized using a transilluminator, which emits UV light. The UV causes the ethidium bromide to fluoresce, revealing bands of fluorescence where DNA is present. Ethidium bromide has a positive charge and thus runs through the gel toward the negative electrode (opposite to the direction of the DNA). If the gel is run too long, the DNA may be difficult to visualize because the ethidium bromide may have traveled too far up the gel.

Gel electrophoresis can be used to verify the size of DNA fragments produced from various reactions. Following completion of gel electrophoresis, the desired DNA fragment(s) can be isolated from the gel if necessary using a gel extraction procedure.

#### Preparing 1% Agarose Gels

1. Measure 0.5 g agarose powder and add it to a 250 mL flask.
2. Add 50 mL 1x TAE buffer to the flask.
3. Dissolve the agarose in a microwave or hot (>95°C) water bath until the solution becomes clear. If using a microwave, heat the solution for several short intervals; do not let the solution boil for long periods as it may boil out of the flask and/or significantly change the concentration of the gel. The agarose is completely dissolved when the solution is completely clear. If you can see swirls or "wind" in the solution, it needs to be heated longer.
4. Let the solution cool to about 50-55°C, swirling the flask occasionally to cool evenly. The solution is cool enough when you can grab the flask with your bare hand (about 5 minutes). **Be careful not to burn yourself**; hot glass looks like cold glass.
5. Add 2-5 µL of ethidium bromide to the solution and swirl to mix. **Caution:** Ethidium bromide is a carcinogen and teratogen. Wear gloves when handling ethidium bromide and whenever handling the gel for the rest of the protocol.
6. Secure the rails on either side of the gel casting tray in the up position such that the gel will not leak out of the tray as it cools. Be gentle when you screw in the rails on the tray, as the screws are delicate.

7. Pour the melted agarose solution into the casting tray.
8. Choose an appropriate comb for the number and volume of samples to be run. Place the comb in the comb slot near the end of the casting tray.
9. Let the gel cool until it is solid (10-20 minutes). It will become more opaque as it cools.
10. Carefully unscrew and lower the rails on the gel box.
11. Place the gel in the electrophoresis chamber **with the wells on the negative (black) end** of the gel box. If the gel is placed in the wrong orientation, the DNA will run off the end of the gel and the sample will be lost!
12. Add enough TAE buffer so that the gel is completely submerged by at least 2-3 mm.
13. Carefully and slowly pull the comb straight up and out of the gel. The gel is now ready to be loaded and run.

#### Loading the Gel

1. Before loading the gel, prepare a chart in the lab notebook to keep track of which sample you will place in each well.
2. Add at least 1  $\mu\text{L}$  loading dye per 5  $\mu\text{L}$  sample and mix thoroughly by pipetting up and down. If you are not using the full volume of a sample (e.g., 5  $\mu\text{L}$  of a 25  $\mu\text{L}$  digest), be sure to mix the loading dye and the portion of the sample to be run in a separate tube so that the remaining sample is preserved.
3. Add 5-15  $\mu\text{L}$  of ladder to an empty well. If you are running many samples, you may want to run ladder in two lanes so that DNA fragment sizes may be determined easily.
4. Add 10-20  $\mu\text{L}$  of each sample to a well using one sample per well. When loading the gel, be careful not to nick the gel or stab through the bottom of the well. Pipette slowly and try to minimize bubbles when retrieving and depositing samples.
5. Run the gel immediately so that the DNA samples do not diffuse out of the wells.

#### Running the Gel

1. Place the lid on the gel box, connecting the electrodes.
2. Connect the electrode wires to the power supply, making sure the positive (red) and negative (black) are correctly connected.
3. Check to make sure the gel is positioned such that wells are near the negative (black) electrode. DNA is negatively charged, so it will run toward the positive red side. Remember "run to red."
4. Turn on the power supply, and set it at 100-150 V.
5. Check to make sure the current is running through the buffer by looking for bubbles forming in the box (more rapidly on the negative side).
6. Check to make sure that the current is running in the correct direction by observing the movement of the blue loading dye after a couple of minutes.

7. Let the gel run until the lower blue dye band is approximately halfway down the gel. If you let the gel run too long, the ethidium bromide and/or the bands will run too far, making the gel difficult or impossible to analyze.
8. Turn off the power supply, and disconnect the wires.
9. Remove the lid of the electrophoresis chamber.
10. Carefully remove the tray and gel. Remember to wear gloves because the gel and buffer both contain ethidium bromide.

## Gel Extraction

After running DNA on a gel, the DNA can be removed and purified through a gel extraction. Many of the steps in a gel extraction are similar to the steps in a miniprep. Purified DNA from gel extraction can be used in ligations, transformations, etc. Our iGEM lab uses the "Gel/PCR DNA Fragments Extraction Kit" from IBI.

### Gel Extraction Protocol

1. Using a sterilized straw, excise the portion of agarose gel containing the desired DNA fragments and remove excess agarose. The gel slice should be no larger than 300 mg.
2. Transfer the gel slice to a 1.5 mL Epi tube.
3. Add 500  $\mu$ L of DF Buffer to the sample, make sure gel slice is in the buffer.
4. Incubate at 55-60°C for 10-15 minutes or until the gel slice has been completely dissolved. To improve efficiency, invert the tube every 2-3 minutes during incubation.
5. Cool the dissolved sample mixture to room temperature.
6. Place a DF Column in a 2 mL Collection Tube.
7. Transfer 800  $\mu$ L of the sample mixture produced in step 5 to the DF Column.
8. Centrifuge at 16,000 x g (max speed) for 30 seconds.
9. Discard the flow-through and place the DF Column back into the 2 mL Collection Tube.
10. Add 600  $\mu$ L of Wash Buffer to the DF Column.
11. Centrifuge at 16,000 x g (max speed) for 30 seconds.
12. Discard the flow-through and place the DF Column back into the 2 mL Collection Tube.
13. Centrifuge again for 3 minutes at 16,000 x g (max speed) to dry the column matrix.
14. Transfer the dried DF Column to a new (labeled) 1.5 mL Epi.
15. Add 15-50  $\mu$ L of Elution Buffer directly to the center of the DF Column filter without touching the pipette tip to the filter. Make sure the buffer absorbs fully into the filter and does not adhere to the side of the column.
16. Let stand for 2 minutes.
17. Centrifuge for 2 minutes at 16,000 x g (max speed) to elute the DNA. Discard the DF Column and store the 1.5 mL Epi containing the extracted DNA in the iGEM freezer.

Commented [L3]: Confirm congruency with kit protocol

**Notes:**

- DF Buffer contains guanidine hydrochloride, which is a harmful irritant. Individuals performing this procedure should wear gloves.
- If the gel slice is too big (>300 mg), the yield is likely to be low. Separate the gel slice into smaller pieces if necessary.
- Preheating the Elution Buffer to 60-70°C may increase the yield when extracting large DNA fragments (>10 kb).

**Commented [L4]:** Add PCR purification protocol (ibi kit)

## Polymerase Chain Reaction (PCR)

*Polymerase Chain Reaction* is a method used to copy a specific segment of DNA (not the entire plasmid or genome). PCR is closely related to DNA replication but results in exponential amplification of the sequence of interest. This reaction requires template DNA, such as a plasmid or chromosome; RNA primers, which are necessary to begin replication of a DNA template; dNTPs, which are the raw materials for forming a new strand of DNA; DNA polymerase, the enzyme responsible for DNA replication; and a buffer to ensure proper reaction conditions. PCR occurs in a three-step process known as a *PCR cycle*. Each cycle consists of the following:

- *Denaturation*: During this step, heat ( $\geq 90^{\circ}\text{C}$ ) is used to separate double-stranded DNA into single strands. This separation is possible because the hydrogen bonds that link base pairs are weakened or broken at high temperatures. The phosphodiester bonds, however, are covalent and remain intact at these temperatures.
- *Annealing*: This step usually takes place between 40 and 65°C. The purpose of this step is for the DNA template to form hydrogen bonds with RNA primers. The beginning of the target sequence on the template strand is marked when the primers anneal (bind) to their complementary sequence on the DNA. Primers are short, synthetic sequences of single-stranded RNA that are designed to be complementary to the DNA sequence of interest. Two primers are used in PCR: a *forward primer* and a *reverse primer*. One primer is needed for each complementary strand of template DNA.
- *Extension*: This step usually takes place at 72°C. During this step, Taq DNA polymerase is used to replicate the DNA strands. Taq is used because it is stable and functional at high temperatures. It begins synthesis at the primers, using the existing DNA as a template to synthesize a complementary strand. This reaction occurs in the 5'→3' direction only. Taq polymerase adds nucleotides to the growing DNA strand by cleaving a diphosphate group from each dNTP, which releases energy that is used to form the phosphodiester bond.

PCR takes place in a thermocycler (PCR machine). This machine controls the temperatures of the reaction. Increasing the number of cycles exponentially increases the number of copies of the DNA sequence. It is typical to use 21-30 cycles.

### PCR Protocol

Our lab uses a commercial "master mix" to run a polymerase chain reaction. This master mix consists of Taq polymerase, deoxynucleoside triphosphates (dNTPs, i.e., adenine, thymine, cytosine, and guanine triphosphates), and polymerase buffer.

1. Briefly spin down the Taq Master Mix (a commercial solution stored in the iGEM freezer).
2. Mix each reaction in its own PCR tube with the following components:

Sterile MilliQ water	calculated for final volume of 25 $\mu$ L
2x Taq Master Mix	12.5 $\mu$ L
Template DNA	up to 100 ng
Forward Primer	0.1-1 $\mu$ M (final concentration)
Reverse Primer	0.1-1 $\mu$ M (final concentration)
3. Mix the reaction gently by pipetting the solution up and down a few times.
4. Spin reaction down for a few seconds in the mini centrifuge.
5. Run the reaction in the thermocycler using the "igem\_pcr" program.
6. If using the PCR product for TOPO-TA cloning, use immediately, do not freeze! Otherwise, the product may be stored in the -20C freezer.

### Sequencing

Sequencing is not done in the iGEM lab. Samples are sent to the cDNA lab for this process, but steps must be taken to prepare a sample for sequencing. Sequencing is expensive and is usually done in large batches. Instructors be responsible for sequencing requests to the cDNA lab. Such requests should be made as far in advance as possible.

### Sequencing Procedure

- Add the following to a 0.2 mL tube:
  - 200-300 ng of clean DNA
  - 3 pM of one primer (either forward or reverse)
- Bring to a total volume of 6  $\mu$ L with MilliQ water.
- Label tubes using ONLY whole numbers (1, 2, 3, 4, etc.), and write key to numbers in lab notebook.

**Commented [L5]:** Change for Mizzou lab

## Sources

- <http://structbio.vanderbilt.edu/chazin/wisdom/labpro/sterile.html>
- <http://www.ruf.rice.edu/~bioslabs/bios318/318manual.htm>
- <http://www.uow.edu.au/content/groups/public/@web/@sci/@chem/documents/doc/uow016883.pdf> (waste)
- <http://www.molcardiology.com/defenitions/100-working-with-NanoDrop-spectrophotometer-tips-and-tricks>
- <http://www.molecularstation.com/forum/pcr-polymerase-chain-reaction-forum/230-agarose-gel-electrophoresis-pcr-products-method-protocol.html>
- <http://www.vivo.colostate.edu/hbooks/genetics/biotech/enzymes/ligation.html>
- <http://web.princeton.edu/sites/ehs/healthsafetyguide/D2.htm>
- [http://mcb.berkeley.edu/labs/krantz/protocols/agar\\_plates.pdf](http://mcb.berkeley.edu/labs/krantz/protocols/agar_plates.pdf)
- <http://bitesizebio.com/articles/the-basics-how-alkaline-lysis-works/>
- <http://bitesizebio.com/articles/the-basics-how-does-dna-ligation-work/>
- <http://syntheticbiology.org/>
- <http://www.synbioproject.org/>
- [igem.org/](http://igem.org/)
- [http://partsregistry.org/Main\\_Page](http://partsregistry.org/Main_Page)
- <http://users.rcn.com/jkimball.ma.ultranet/BiologyPages/B/BasePairing.html>



## Appendix A – Glossary

**amino acids** – the building blocks of proteins; they are composed of a carboxyl group (COOH), an amino group (NH<sub>2</sub>), and a functional group (R); the electro-chemical properties of the functional group dictates the identity and bonding behavior of the amino acid.

**annealing** – the formation of hydrogen bonds between complementary sequences of single-stranded DNA and/or RNA, which results in a double-stranded segment.

**antiparallel** – the term used to describe the opposite orientations of the two strands of a piece of double-stranded DNA; the 5'→3' strand is complementary to the 3'→5' strand.

**base pair** – two complementary nitrogenous bases held together by hydrogen bonding (adenine with thymine, or guanine with cytosine). The two strands of DNA are held together by these hydrogen bonds between base pairs.

**BioBrick** – a standardized type of recombinant DNA used by iGEM in the Registry of Standard Biological Parts that is flanked with the iGEM prefix and suffix.

**blunt ends** – a digested (or "cut") double-stranded DNA fragment that contains no single-stranded overhang on either side of the cut.

**chemical transformation** – method of transformation that utilizes chemically competent cells and temperature shock to induce the cells to uptake foreign genetic material.

**chemically competent cells** – cells that have been chemically treated to induce the ability to uptake DNA from their environment.

**codon** – a sequence of three nucleotides that codes for a specific amino acid.

**competence** – the ability of a cell to take up foreign genetic material from its environment; cells can be naturally competent, or competence can be induced to make cells chemically competent or electrically competent.

**conjugation** – the process by which two cells come in contact via a pilus (tube-like extension of cell membrane) and exchange genetic material. Conjugation can only be initiated by certain types of cells.

**cut and paste** – the informal term for restriction digest and ligation, respectively.

**denaturation** – the separation of two strands of a DNA double helix, or the disruption of the hydrogen bonded structure of any complex molecule (e.g., protein) without breaking the covalent bonds in the molecule.

**DNA** – an antiparallel double helix of deoxynucleotides linked by phosphodiester (sugar-phosphate) bonds between adjacent nucleotides in the same chain, and by hydrogen bonds between complementary nucleotides on the opposite chain; the fundamental substance of which genes are composed.

**DNA double helix** – the normal structural configuration of double-stranded DNA, consisting of two right-handed helices winding about the same axis.

**DNA ligase** – an enzyme that creates a phosphodiester bond between segments of one of the strands of DNA in a piece of double-stranded DNA. It can be used to close nicks made by restriction enzymes.

**electrically competent cells** – cells that are capable of taking up foreign genetic material via electroporation.

**electroporation (electrical transformation)** – a transformation technique that utilizes the application of a high-voltage electrical pulse, which creates nm-scale hydrophilic holes in the cell membrane, allowing foreign DNA to enter the cell.

**extension** – the addition of nucleotides to the 3' end of a strand of DNA or RNA that is being synthesized (e.g., during replication or transcription).

**forward primer** – a short segment of RNA (approximately 18-24 bases in length) used in PCR. It is designed to anneal to a complementary sequence of DNA at the 5' end of the sequence of interest on the 5'→3' strand. RNA primers are needed to initiate extension for the DNA segment of interest.

**hydrogen bond** – a weak, noncovalent bond between hydrogen and an electronegative atom such as nitrogen or oxygen. Hydrogen bonds between complementary base pairs are solely responsible for holding the two strands of the DNA double helix together.

**ligation** – the formation of a phosphodiester bond between the 3' hydroxyl of one nucleotide and the 5' phosphate of an adjacent nucleotide. Ligations are performed by the enzyme DNA ligase.

**lysis** – the process by which the cell membrane (and wall) are disrupted by physical or chemical means, causing cellular contents to be released from cells.

**messenger RNA (mRNA)** – the protein-coding RNA; the RNA that relays information from DNA to the ribosomes (sites of protein synthesis) in the cell so that they can be translated into proteins.

**miniprep** – a type of plasmid purification (process by which plasmid DNA is removed from cells and purified).

**nucleotide** – a molecule consisting of a nitrogenous base (adenine, guanine, thymine, cytosine, or uracil), a sugar (ribose or deoxyribose), and a phosphate group (triphosphate, diphosphate, or monophosphate). Nucleotides are the basic units of nucleic acids (DNA and RNA).

**PCR (Polymerase Chain Reaction)** – the cyclical series of reactions (PCR cycles) by which a specific segment of double-stranded DNA can be copied many times, or amplified.

**PCR cycle** – a programmed series of three different reaction temperatures corresponding to the processes of PCR: annealing, denaturation, and extension. The temperatures selected will depend on the chemical properties of the DNA of interest and RNA primers being used.

**peptide bond** – the covalent bond between the amine group on one amino acid and the carboxyl group of the adjacent amino acid in a polypeptide.

**phosphodiester bond (phosphodiester linkage)** – the covalent bond between the 3' hydroxyl of one nucleotide and the 5' phosphate of an adjacent nucleotide in DNA or RNA. These bonds form the "backbone" of DNA and RNA strands. This bond is broken in a restriction digest and formed in a ligation.

**plasmid** – a small, circular extra-chromosomal piece of DNA that can replicate independently of the chromosomes and is transferrable to other cells. In nature and in the lab, plasmids often contain antibiotic resistance. Plasmids can be present in a cell in multiple copies.

**polypeptide** – an organic polymer consisting of a chain of amino acids linked together by peptide bonds, forming all or part of a protein molecule.

**prefix** – the term used by iGEM to describe the standardized DNA sequence that precedes the 5' end of a BioBrick and contains the EcoRI and XbaI restriction sites.

**promoter** – a region in a DNA sequence (usually at the beginning of a gene) that is recognized by transcription factors and RNA polymerase, allowing them to bind and initiate the transcription of RNA. Different promoters have variable affinity for the transcription factors, resulting in intrinsic promoter strength.

**protein** – a large organic molecule that is composed of one or more polypeptides; proteins have a variety of functions within cells (e.g., enzymes, structural proteins, and signaling proteins).

**recombinant DNA** – DNA molecules that are intentionally assembled through genetic manipulation, and usually contain DNA from multiple source organisms.

**restriction digest** – the reaction in which double-stranded DNA is cut at a specific sequence by a restriction enzyme.

**restriction enzyme** – an enzyme that cuts the phosphodiester backbone of DNA at a specific sequence called the restriction site. Each restriction enzyme recognizes a unique restriction site and cuts the DNA in a specific pattern.

**restriction site** – the specific DNA sequence at which a restriction enzyme will cut a DNA molecule.

**reverse primer** – a short segment of RNA (approximately 18-24 bases in length) used in PCR. It is designed to anneal to a complementary sequence of DNA at the 5' end of the sequence of interest on the 3'→5' strand. RNA primers are needed to initiate extension for the DNA segment of interest.

**ribosomal RNA (rRNA)** – the RNA component of a ribosome.

**ribosome binding site (RBS)** – the specific sequence in an mRNA molecule to which a ribosome will bind to begin translation. This is also called the Shine-Dalgarno sequence.

**satellite colony** – a colony of microbes that does not contain the plasmid of interest (and thus the antibiotic resistance gene on the plasmid). These colonies can grow in the antibiotic-free area that develops around a resistant colony.

**standard assembly** – the standardized molecular cloning method used in synthetic biology, including iGEM.

**sticky ends** – the short single-stranded overhangs at the end of a digested double-stranded

segment of DNA. These overhangs will always be complementary to each other when the DNA is cut with the same restriction enzyme, and some complementary sticky end sequences can be formed by different restriction enzymes.

**suffix** – the term used by iGEM to describe the standardized DNA sequence that follows the 3' end of a BioBrick and contains the SpeI and PstI restriction sites.

**termination sequence** – a three-base sequence (codon) on an mRNA that terminates protein synthesis.

**transcript** – the RNA molecule that is synthesized from a DNA template; the product of transcription.

**transcription** – the process by which RNA polymerase uses DNA as a template to produce a complementary strand of RNA.

**transduction** – the process by which genetic material is transferred from one bacterium to another via a bacteriophage (a type of virus).

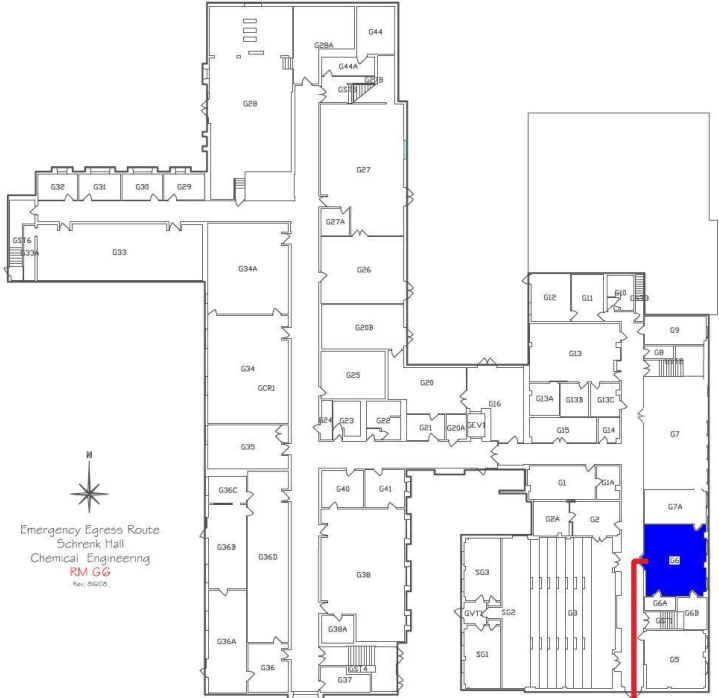
**transfer RNA (tRNA)** – the type of RNA that carries amino acids to the ribosome during translation. Each tRNA binds to a specific amino acid and contains an anti-codon that is complementary to a corresponding codon on the mRNA.

**transformation** – the process by which foreign genetic material from the environment is taken up by a cell. Transformation can be natural, chemically induced, or electrically induced.

**translation** – the process by which mRNA is "decoded" (using ribosomes and tRNA) to produce a specific sequence of amino acids, and thus a polypeptide.

**vector** – a plasmid used in genetic engineering. In ligation, "vector" refers to the longer DNA segment into which the shorter DNA segment (insert) will be integrated.

Appendix B – Egress Map



## Appendix C – Lab Notebook Example

### Lab Notebook Example Entries

Date: 3/03/13

Name: Joe Microbe

Start Time: 11:00 am

Mini-prep of cultures containing BBa\_J000333

**Purpose:** To purify the plasmid containing BBa\_J000333 from the cultures labeled 3/2/13 LC 1, 3/2/13 LC 2, and 3/2/13 LC 3 using the High-Speed Plasmid Mini Kit from IBI.

**Protocol:** This miniprep was done using the protocol that came with the High-Speed Plasmid Mini Kit from IBI except for the following variations:

- 1.) During the elution step, MilliQ water was used instead of the Elution Buffer provided in the kit.
- 2.) The resulting samples were then NanoDropped to determine quality and concentration.

**Products:** The following Table describes the samples produced:

Sample Label	Source Sample Label	Description
3/3/13 Mp 1	3/2/13 LC 1	Purified plasmid containing BBa_J000333 part
3/3/13 Mp 2	3/2/13 LC 2	Purified plasmid containing BBa_J000333 part
3/3/13 Mp 3	3/2/13 LC 3	Purified plasmid containing BBa_J000333 part

**Results:** NanoDrop results:

Sample	Concentration (ng/μL)	260nm/280nm	260nm/230nm
3/3/13 Mp 1	115.3	1.79	2.1
3/3/13 Mp 2	221.7	1.92	2.3
3/3/13 Mp 3	179.2	1.85	2.1

**Notes:** N/A

**Stop Time:** 12:00 pm

**Next:** These samples need to be digested with XbaI and PstI and run on a gel. The BBa\_J000333 part fragment (~750 bp) should then be extracted and purified.

**Start Time:** 12:15 pm

Digestion of plasmids containing BBa\_J000333 part with XbaI and PstI.

**Purpose:** The samples 3/3/13 Mp 1, 3/3/13 Mp 2 and 3/3/13 Mp 3 each contain the purified plasmid with the BBa\_J000333 part. The BBa\_J000333 part is flanked by XbaI upstream

and PstI downstream. The purified plasmids will each be digested with XbaI and PstI so that the BBa\_J000333 part can be isolated for downstream applications.

Protocol: 1.) The following reactions were mixed in a PCR tube for each of the miniprep samples:

For 3/3/13 Mp 1:

Reagent	Amount
10x Buffer Tango	2.5 $\mu$ L
3/3/13 Mp 1	8.5 $\mu$ L
XbaI	1 $\mu$ L
PstI	1 $\mu$ L
MilliQ H <sub>2</sub> O	12 $\mu$ L

For 3/3/13 Mp 2:

Reagent	Amount
10x Buffer Tango	2.5 $\mu$ L
3/3/13 Mp 2	4.5 $\mu$ L
XbaI	1 $\mu$ L
PstI	1 $\mu$ L
MilliQ H <sub>2</sub> O	16 $\mu$ L

For 3/3/13 Mp 3:

Reagent	Amount
10x Buffer Tango	2.5 $\mu$ L
3/3/13 Mp 3	5.5 $\mu$ L
XbaI	1 $\mu$ L
PstI	1 $\mu$ L
MilliQ H <sub>2</sub> O	15 $\mu$ L

- 2.) Each tube was mixed by flicking and spun down in the mini centrifuge.
- 3.) Each tube was placed in the thermocycler and run under the program "igem/digest"
- 4.) The products were stored in the G6A freezer in "box C."

Products: The following Table describes the samples produced:

Sample Label	Source Sample Label	Description
3/3/13 D 1	3/3/13 Mp 1	BBa_J000333 digested with XbaI and PstI
3/3/13 D 2	3/3/13 Mp 2	BBa_J000333 digested with XbaI and PstI
3/3/13 D 3	3/3/13 Mp 3	BBa_J000333 digested with XbaI and PstI

Results: N/A

Notes: N/A

Stop Time: 2:15 pm



Next: The digested samples need to be run on a gel to separate fragments. The relevant fragment (the BBa\_J000333 part fragment, ~750 bp) needs to be extracted from the gel and purified.

---

Date: 3/4/13 Name: Joe Microbe

---

Start Time: 10:00 am

Gel Electrophoresis of 3/3/13 D 1, 3/3/13 D 2, and 3/3/13 D 3.

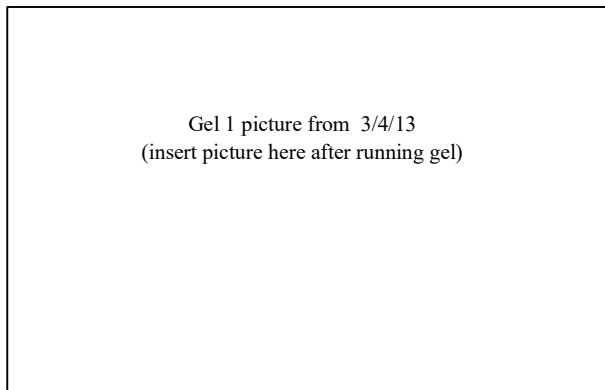
Purpose: The 3 double digests will be run on a gel to help verify the presence of the BBa\_J000333 part (it should be ~ 750 bp long) in each of the digests, and to separate the BBa\_J000333 fragment from the rest of the plasmid. The part fragment will later be extracted and purified for downstream applications.

Protocol: The 3 digests were run on an 8-well gel using the gel electrophoresis protocol described on pg. 35 of the Missouri S&T iGEM Lab Training Manual, edition 1. The setup of the gel is illustrated in the following table:

Well	1	2	3	4	5	6	7	8
Sample	Lambda Ladder	3/3/13 D 1	3/3/13 D 2	3/3/13 D 3				

Products: N/A

Results:



Notes: N/A

Stop Time: 11:00 am

Next: The BBa\_J000333 fragment (~750 bp long) should be extracted from the gel and purified so that it can be ligated into an iGEM standard vector downstream of the BBa\_K301311 part.

Start Time: 11:15 am

Gel Extraction of ~750 bp long fragment from 3/4/13 Gel 1

Purpose: The fragment of interest (BBa\_J000333 part) is ~750 bp long. This fragment will be extracted from the 3/4/13 Gel 1 to obtain purified BBa\_J000333 part fragment for ligation into standard iGEM vector downstream of the BBa\_K301311 part. The IBI Gel Extraction Kit will be used.

Protocol: The protocol provided with the IBI Gel Extraction Kit was used with no variations except that 300 mg of gel slice was used in each of three extractions.

Products: 50 µL of purified BBa\_J000333 fragment in each tube. The following table describes the samples and their labeling:

Sample Label	Source Sample Label	Description
3/4/13 GE 1	3/3/13 D 1	BBa_J000333 (~750 bp) Extracted from well 2
3/4/13 GE 2	3/3/13 D 2	BBa_J000333 (~750 bp) Extracted from well 3
3/4/13 GE 3	3/3/13 D 3	BBa_J000333 (~750 bp) Extracted from well 4

Results: N/A

Notes: The 3/4/13 GE 2 sample was dropped between steps 5 and 6 of the gel extraction. Part of the sample was lost, but enough remained to complete the procedure.

Stop Time: 11:00 am

Next: The 3/4/13 GE 1, 3/4/13 GE 2 and 3/4/13 GE 3 BBa\_J000333 fragments should be ligated into a vector that includes only the BBa\_K301311 part and has been digested with PstI and SpeI. The resultant plasmid should contain BBa\_K301311 with BBa\_J000333 immediately downstream.

Start Time: 11:15 am

Digestion of plasmid containing BBa\_K301311 with SpeI and PstI

Purpose: The BBa\_K301311 plasmid will be cut with SpeI (to correspond with XbaI) and PstI (to correspond with PstI). The products of the 3/4/13 gel extractions will later be ligated into the BBa\_K301311 plasmid.

Protocol: 1.) A reaction was mixed for each 2/27/13 Mp sample in a PCR tube according to the following tables:

For 2/27/13 Mp 1

Reagent	Amount
10x Tango Buffer	2.5 $\mu$ L
2/27/13 Mp 1	4.5 $\mu$ L
SpeI	1 $\mu$ L
PstI	1 $\mu$ L
Sterile MilliQ H <sub>2</sub> O	16 $\mu$ L

For 2/27/13 Mp 2

Reagent	Amount
10x Tango Buffer	2.5 $\mu$ L
2/27/13 Mp 2	3.5 $\mu$ L
SpeI	1 $\mu$ L
PstI	1 $\mu$ L
Sterile MilliQ H <sub>2</sub> O	17 $\mu$ L

For 2/27/13 Mp 3

Reagent	Amount
10x Tango Buffer	2.5 $\mu$ L
2/27/13 Mp 3	4.5 $\mu$ L
SpeI	1 $\mu$ L
PstI	1 $\mu$ L
Sterile MilliQ H <sub>2</sub> O	16 $\mu$ L

- 2.) Each tube was mixed by flicking and spun down in the mini centrifuge.
- 3.) Each tube was placed in the thermocycler and run under the program "igem/digest".

Products: The following table describes the samples and their labeling:

Sample Label	Source Sample Label	Description
3/4/13 D 1	2/27/13 Mp 1	BBa_K301311 vector digested with SpeI and PstI
3/4/13 D 2	2/27/13 Mp 2	BBa_K301311 vector digested with SpeI and PstI
3/4/13 D 3	2/27/13 Mp 3	BBa_K301311 vector digested with SpeI and PstI

Results: N/A

Notes: N/A

Stop Time: 12:10 pm

Next: The BBa\_J000333 fragments (3/4/13 GE 1, GE 2, and GE 3) need to be ligated into the

3/4/13 digestions of the BBa\_K301311 linearized plasmid. The resultant plasmid should be transformed into DH5alpha cells.

Date: 3/5/13

Name: Joe Microbe

Start Time: 10:00 am

Ligation of the BBa\_J000333 part into a the plasmid with the BBa\_K301311 part

Purpose: The BBa\_J000333 part will be ligated into a plasmid containing the BBa\_K301311 downstream of the BBa\_K301311 part. The ligation reactions will include the 3/4/13 GE 1, 2, and 3 for BBa\_J000333 part fragment (which includes XbaI and PstI sticky ends) and the 3/4/13 D 1, 2, and 3 for the linearized vector containing the BBa\_K301311 part (which includes SpeI and PstI sticky ends).

Protocol: 1.) The following ligation reactions were mixed in three PCR tubes:

Tube 1

Reagent	Amount
3/4/13 D 1	2 $\mu$ L
3/4/13 GE 1	2 $\mu$ L
10x T4 DNA Ligase Buffer	2 $\mu$ L
T4 DNA Ligase	1 $\mu$ L
Sterile MilliQ H <sub>2</sub> O	13 $\mu$ L

Tube 2

Reagent	Amount
3/4/13 D 2	2 $\mu$ L
3/4/13 GE 2	2 $\mu$ L
10x T4 DNA Ligase Buffer	2 $\mu$ L
T4 DNA Ligase	1 $\mu$ L
Sterile MilliQ H <sub>2</sub> O	13 $\mu$ L

Tube 3

Reagent	Amount
3/4/13 D 3	2 $\mu$ L
3/4/13 GE 3	2 $\mu$ L
10x T4 DNA Ligase Buffer	2 $\mu$ L
T4 DNA Ligase	1 $\mu$ L
Sterile MilliQ H <sub>2</sub> O	13 $\mu$ L

2.) The ligations were run in the thermocycler under the program "igem/lig".

Products:

Sample Label	Source Sample Labels	Description
3/5/13 L 1	Insert: 3/4/13 GE 1 Vector: 3/4/13 D 1	Plasmid containing BBA_K301311 upstream of BBA_J000333
3/5/13 L 2	Insert: 3/4/13 GE 2 Vector: 3/4/13 D 2	Plasmid containing BBA_K301311 upstream of BBA_J000333
3/5/13 L 3	Insert: 3/4/13 GE 3 Vector: 3/4/13 D 3	Plasmid containing BBA_K301311 upstream of BBA_J000333

Results: N/A

Notes: N/A

Stop Time: 12:00 pm

Next: The products of this procedure should be transformed into DH5alpha cells and screened for successful transformants. The BBA\_K301311 part is a constitutive promoter. Successfully transformed cells should display red fluorescence.

Start Time: 12:15 pm

Chemical transformation of 3/5/13 L 1, 2, and 3 into DH5alpha cells

Purpose: The BBA\_J000333 part codes for the red fluorescence protein. The BBA\_K301311 part is a constitutive promoter. The 3/5/13 L 1, 2, and 3 plasmids, with which the DH5alpha cells will be transformed, include BBA\_K301311 followed by BBA\_J000333. Successfully transformed cells should display red fluorescence.

Protocol: Three vials of DH5alpha chemically competent cells were each transformed with 3/5/13 L 1, 3/5/13 L 2, or 3/5/13 L 3 using the chemical transformation protocol as seen on pg. 42 of the Lab Manual edition 2.

Products: The following cultures were produced:

Sample Label	Source Sample Label	Description
3/5/13 CT 1	3/5/13 L 1	Transformed DH5alpha cells
3/5/13 CT 2	3/5/13 L 2	Transformed DH5alpha cells
3/5/13 CT 3	3/5/13 L 3	Transformed DH5alpha cells

Results: See 3/5/13 CT results entry for following day.

Notes: 1.) The plates were placed in the 37°C incubator for the night.  
2.) Successful transformations should fluoresce red.

Stop Time: 3:45pm

Next: The 3/5/13 CT 1, 2 and 3 plates should be removed from the incubator in the morning on 3/6/13 and screened for red fluorescing colonies. Said colonies should be isolated and used to inoculate LB Ampicillin broth tubes.

Date: 3/6/13

Name: Joe Microbe

Start Time: 10:00 am

Isolation of red fluorescing colonies grown from 3/5/13 CT 1, 2 and 3

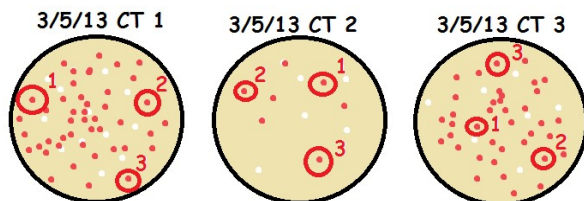
Purpose: The plates will be screened for red fluorescing colonies. These are the colonies that contain the correct plasmid. The plasmid should include a red fluorescence part (BBa\_J000333) preceded by a constitutive promoter (BBa\_K301311).

Protocol: 3 red colonies were used to inoculate from each of the 3/5/13 CT 1, 2 and 3 into LB ampicillin broth.

Products: The resultant LB amp cultures are described in the following table:

Sample Label	Source Sample Label	Description
3/6/13 I 1	3/5/13 CT 1	Isolation and inoculation of colony 1
3/6/13 I 2	3/5/13 CT 1	Isolation and inoculation of colony 2
3/6/13 I 3	3/5/13 CT 1	Isolation and inoculation of colony 3
3/6/13 I 4	3/5/13 CT 2	Isolation and inoculation of colony 1
3/6/13 I 5	3/5/13 CT 2	Isolation and inoculation of colony 2
3/6/13 I 6	3/5/13 CT 2	Isolation and inoculation of colony 3
3/6/13 I 7	3/5/13 CT 3	Isolation and inoculation of colony 1
3/6/13 I 8	3/5/13 CT 3	Isolation and inoculation of colony 2
3/6/13 I 9	3/5/13 CT 3	Isolation and inoculation of colony 3

The following images are 3/5/13 CT 1, 2 and 3 with the three colonies that were taken from each indicated and numbered. *[This photo or drawing does not need to go in the lab notebook; you just need to circle and number the colony on the bottom of the plate.]*



Results: N/A

Notes: N/A

Stop Time: 10:30 am

Next: 3/6/13 I cultures 1-9 should be minipreped. The resultant plasmid should be double digested with EcoRI and SpeI and run on a gel to verify the presence of both the BBa\_J000333 and the BBa\_K301311 parts.

## Appendix D – Preparation and Supplies

The following section contains procedures and recipes for materials commonly used in the iGEM lab.

### Filling Tip Boxes

Pipette tips in the iGEM lab are autoclaved before use. The tips we use come in bulk bags and are not sterile. After all tips in a tip box are used, the box must be refilled from the bag and autoclaved. There are designated areas in the lab for tip boxes that need to be filled and filled tip boxes that need to be autoclaved. If you see empty tip boxes and have downtime during labwork, you should fill the tip boxes. An Instructor will autoclave the tip boxes for you.

#### Procedure

1. Determine the correct size tip for the tip box you are going to fill. Tips come in three sizes: 10, 200, and 1000  $\mu\text{L}$ .
2. Fill the box with the correct tips.
3. Place a small strip of autoclave tape over the latch of the tip box.
4. Place the filled box in the "to be autoclaved" area.

### LB Broth

1. Mix the following into 1000 mL of MilliQ water:
  - 10 g tryptone
  - 5 g yeast extract
  - 5 g NaCl
2. Stir solution using a magnetic stir bar and a stir plate until all ingredients are completely dissolved.
3. Adjust pH to 7.0 with NaOH. This step is optional, depending on the pH sensitivity of the organism. We generally do not adjust the pH when working with *E. coli*.
4. Distribute into tubes (5 mL per tube) or bottles (100 mL per bottle).
5. Put a small strip of autoclave tape on the bottles or on the tube rack.
6. Ask an Instructor to autoclave the media.
7. Sterile glucose solution may be added after autoclaving, typically 1 g/L final concentration, when needed.

### Pouring LB Agar Plates

1. Mix the following into 700 mL of MilliQ water:
  - 7 g tryptone
  - 3.5 g yeast extract



- 3.5 g NaCl
- 10.5 g agar
- 2. Stir solution using a magnetic stir bar and a stir plate. The agar will not dissolve until autoclaved, but all other ingredients will dissolve at room temperature.
- 3. Ask an Instructor to autoclave the media.
- 4. Allow flask to cool on bench or in a preheated water bath until it is approximately 50-55°C (the flask should be warm to the touch but cool enough to grasp for several seconds without burning your hands). Do not allow the solution to cool enough to solidify in the flask.
- 5. Add the appropriate amount of the desired antibiotic (see antibiotic and concentration sections) and mix by swirling. It is important not to add antibiotics when the media is too hot because the heat can degrade the antibiotics.
- 6. Pour plates (see pouring plates section). This recipe should be enough for about 25 plates (1 bag).

### SOB

1. Mix the following into 250 mL of MilliQ water:
  - 5 g tryptone
  - 1.25 g yeast extract
  - 0.15 g NaCl (10 mM final concentration)
  - 0.05 g KCl (10 mM final concentration)
2. Stir solution using a magnetic stir bar and a stir plate until all ingredients are completely dissolved.
3. Put a small strip of autoclave tape on the flask.
4. Ask an Instructor to autoclave the media.
5. After autoclaving, **aseptically** add:
  - 2.5 mL of 1 M MgSO<sub>4</sub> (10 mM final concentration)
  - 2.5 mL of 1 M MgCl<sub>2</sub> (10 mM final concentration)

### SOC

1. Make SOB.
2. **Aseptically** add 20 mL of 1 M **sterile** glucose per 1000 mL SOB medium.

### Antibiotic and Chemical Stocks

In the iGEM lab, ampicillin and chloramphenicol are the most commonly used antibiotics. For plates, antibiotics are added to the media after autoclaving and allowing the media time to cool, but before pouring the plates. For liquid cultures, antibiotics are added just before inoculation. Refer to the following procedures to prepare antibiotic stock solutions.

#### 1000x Ampicillin Stock Preparation

1. Add 0.5 g ampicillin (powdered and refrigerated) to 5 mL MilliQ water. We typically use a 10 mL sterile plastic tube with a snap cap.
2. Mix by gently inverting the tube until the ampicillin is completely dissolved.
3. If precipitate remains, adjust pH to 7.0 with NaOH.
4. Label the tube "1000x ampicillin MM/DD/YYYY."
5. Place the ampicillin stock in the can in the door of the iGEM refrigerator.

#### 1000x Chloramphenicol Stock Preparation

1. Add 0.25 g chloramphenicol (powdered) to 5 mL ethanol. We typically use a 10 mL sterile plastic tube with a snap cap.
2. Mix by gently inverting the tube until the chloramphenicol is completely dissolved.
3. Label the tube "1000x chloramphenicol MM/DD/YYYY."
4. Place the chloramphenicol stock in the can in the door of the iGEM refrigerator.

#### 1000x Kanamycin Stock Preparation

1. Add 0.25 g kanamycin (powdered) to 5 mL MilliQ water. We typically use a 10 mL sterile plastic tube with a snap cap.
2. Mix by gently inverting the tube until the kanamycin is completely dissolved.
3. Label the tube "1000x kanamycin MM/DD/YYYY."
4. Place the chloramphenicol stock in the can in the door of the iGEM refrigerator.

#### 1000x X-gal Stock Preparation (Note: X-gal is not an antibiotic)

1. Add 0.2 g x-gal (powdered) to 5 mL dimethyl formamide. We typically use a 10 mL sterile plastic tube with a snap cap.
2. Mix by gently inverting the tube until the x-gal is completely dissolved.
3. Adjust pH to 7.0 with NaOH and/or HCl.
4. Label the tube "1000x X-gal MM/DD/YYYY."
5. Place the x-gal stock in the can in the door of the iGEM refrigerator.

#### **Preparing Frozen Stock Cells**

1. Add 750  $\mu$ L liquid cell culture to 750  $\mu$ L of 40% glycerol in each of three appropriately labeled 1.5 mL Epi tubes.
2. Gently invert to mix.
3. Freeze and store at  $-80^{\circ}\text{C}$ .

Note: Stock solutions can be made in duplicate and stored in separate freezers in case of freezer malfunction.

## Making Chemically Competent Cells

Commented [L6]: Add new protocol once found

1. Inoculate 3 mL of LB medium with DH5 $\alpha$  seed stock and incubate the culture overnight at 37°C.
2. Add the overnight culture to 50 mL of SOB and incubate the culture at 37°C until the absorbance at 600 nm is approximately 0.5 (this takes about 2 hours).
3. Chill the culture for at least 10 minutes on ice. **In the following steps, the cell suspension should be kept on ice as much as possible.**
4. Separate the culture into 1 mL aliquots in pre-chilled Epi tubes.
5. Centrifuge the cells for 10 minutes at 4,500 - 6,000 rpm at 4°C. Decant supernatant.
6. Gently resuspend the pellets in 200  $\mu$ L ice-cold TB buffer.
7. Incubate the cell suspension on ice for 10 minutes.
8. Centrifuge for 10 minutes at 4,500 - 6,000 rpm at 4°C. Decant supernatant.
9. Gently resuspend the pellets in 38  $\mu$ L ice-cold TB buffer and add 3  $\mu$ L DMSO.
10. Incubate the cell suspension in ice water for at least 10 minutes.
11. Store at -80°C.

## Making Electrocompetent Cells

Note: Once the cells are grown and have been placed in the first ice bath, you do not want the temperature of the sample to rise above 4 °C at any point. Therefore, many of the instructions are given with this in mind; always think ahead to the next step and to how you are going to keep your cells from warming up. This includes prechilling tubes and keeping all wash materials and samples on ice.

### Materials:

- GYT (glycerol, yeast extract, tryptone)
  - 10%(v/v) glycerol
  - 0.125% (w/v) yeast extract
  - 0.25% (w/v) tryptone
- DI water
- 10% Glycerol

### Protocol:

1. Inoculate 50 mL of LB media with DH5 $\alpha$  seed stock and incubate the culture overnight at 37°C in shaking incubator.
2. Inoculate two aliquots of 475 mL of pre-warmed LB medium in separate 2-liter flasks with 25 mL of the overnight bacterial culture. Incubate the flasks at 37°C in the shaking incubator until the absorbance at 600 nm is approximately 0.6-1.0 (this takes about 2 hours)

3. Transfer the flasks to an ice water bath for 15-30 minutes. Swirl the culture occasionally to ensure that cooling occurs evenly. In preparation for the next step, place the centrifuge bottles in the ice water bath. **In the following steps, the cell suspension should be kept on ice as much as possible (the cells should not be warmer than 4°C).**
4. Transfer the cultures to ice-cold centrifuge tubes. Centrifuge at 1000 x g (2500 rpm) for 15 minutes at 4°C. Decant the supernatant.
5. Resuspend the cell pellets in 1 mL of ice-cold MilliQ water.
6. Centrifuge at 1000 x g (2500 rpm) for 20 minutes at 4°C. Decant the supernatant.
7. Resuspend each cell pellet in 0.5 mL ice-cold MilliQ water.
8. Centrifuge at 1000 x g (2500 rpm) for 20 minutes at 4°C. Decant the supernatant.
9. Resuspend the cell pellet in 20 µL ice-cold 10% glycerol.
10. Centrifuge at 1000 x g (2500 rpm) for 20 minutes at 4°C. Carefully decant the supernatant and use a pipette to remove any remaining drops of buffer.
11. Resuspend the cell pellet in 40 µL ice-cold GYT.
12. Measure the OD-600 of a 1:5 dilution of one of the tubes of GYT suspended cells. (In the cuvette, mix 0.99 mL water and 0.01 mL cell suspension). The OD-600 should be approximately 3.75 after the 1:100 dilution.
13. Dilute the cell suspension to approximately  $2 \times 10^{10}$  to  $3 \times 10^{10}$  cells/mL with ice-cold GYT medium (1.0 OD-600  $\approx 2.5 \times 10^8$  cells/mL).
14. Dispense 40 µL aliquots of the cell suspension into sterile, ice-cold 1.5 mL Epi tubes.
15. Store cells at -80°C.

## Appendix E – Lab Equipment

Commented [GKM(7)]: Add G7A spectrophotometer for culture OD600 measurements?

### Autoclave

Autoclaving is a common way of sterilizing scientific equipment and media. While simply boiling an item in water at normal pressure kills most microbes, it won't kill them all. An autoclave pressurizes its chamber to 15 psi, which achieves a temperature of 121°C without boiling any liquids. This temperature will kill almost all bacteria and spores, effectively sterilizing the items inside.

**As a Trainee or Dependent Lab Worker, you will not be authorized to use the autoclave.** The autoclave is a dangerous piece of equipment that can be easily broken if misused, and thus requires special training to use safely. Only lab workers officially trained in autoclave operation are authorized to use it.

When preparing items to be autoclaved, always place autoclave tape on the items. This tape is blue with white stripes. During autoclaving, the white stripes on the tape will turn brown or black, indicating that the autoclave has reached proper temperature and pressure. Use one small piece of tape per item. Do not use excessive amounts of this tape and never use it for other purposes, including labeling.

Note: Be **very careful** when handling recently autoclaved items. They are very hot and must be handled with autoclave gloves to avoid burns. The liquids are superheated and jostling may unexpectedly cause aggressive boiling and contents may overflow.

### Microcentrifuge



Figure 14 – Microcentrifuge front panel

When using the microcentrifuge, it is **very** important to make sure that the samples are placed in the machine so that the rotor is balanced. Proper balancing of the microcentrifuge is achieved by placing samples in the rotor with radial symmetry by weight. Improperly balancing

the centrifuge can damage the rotor. Examples of a properly balanced centrifuge are shown in Figures 15 and 16. If the samples you have cannot be properly balanced, you will have to make a "fake" sample. This means you will use water to fill an empty tube with the same volume as the tube directly opposite it.



**Figure 15** – A balanced rotor in which each tube is opposite another tube with the **same volume**.



**Figure 16** – A balanced rotor in which tubes of the **same volume** are spaced evenly around the rotor.

**Never** start the centrifuge without securing the inner lid. You should hear a click when the lid is securely latched.

### Centrifuge Operating Instructions

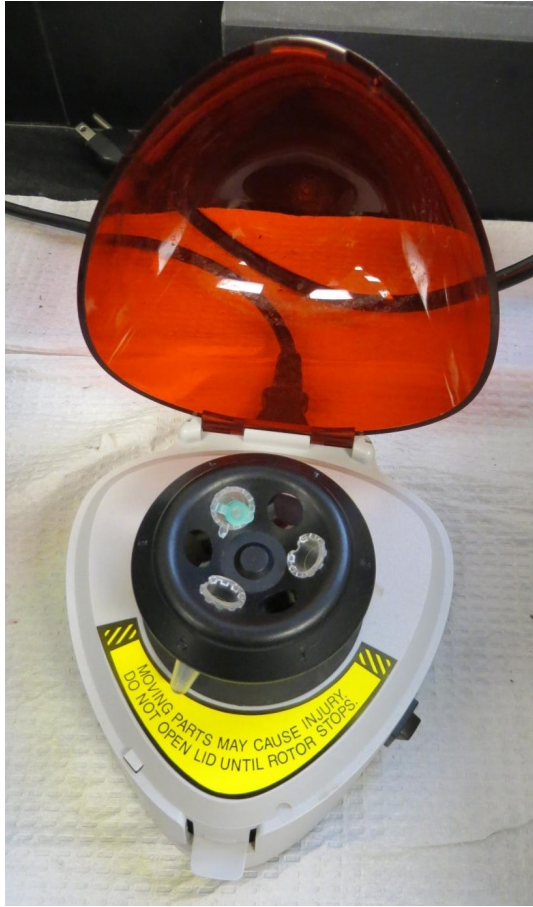
1. Set the desired values for the time and speed of rotation. The white up/down buttons on the left of the control panel will set the speed. The unit of rotation can be switched between g-force and rpm using the central gray up/down button. The time can then be selected using the white up/down buttons on the right of the panel.
2. Load samples, making sure that they are **properly balanced**.
3. Replace the inner lid. A click indicates that it is secured.
4. Close the outer lid of the centrifuge.
5. Press the start button to begin centrifuging. The bottom of the panel contains a set of four operational buttons. The start button is located in the bottom left corner of this set and contains a rightward facing triangle.
6. To stop the centrifuge before the allotted spin time has elapsed, press the button with the red square. This is located to the right of the start button.
7. To open the lid, press the button located above the stop button to unlock it.
8. If the machine is running and reducing the spin time is desired, press the "fast-forward" button above the start button.

Note: The force applied by the same rpm will vary depending on rotor diameter. However, gravity (g-force) is standard between machines.

### **Mini centrifuge**

This is a much simpler instrument than the microcentrifuge, and is typically used to quickly spin down the contents of a tube to collect them in the bottom of the tube. The mini centrifuge has a simple on/off switch and no speed controls. It can be used to spin 1.5 mL Epis or 0.2 mL PCR tubes. When spinning the PCR tubes, make sure you place the PCR tube in a larger tube to hold it (there are "holder tubes" already in the mini centrifuges for this purpose). It is not necessary to balance samples in the mini centrifuge.

To operate the mini centrifuge, place tubes in the rotor, close the lid, and flip the on/off switch. The centrifuge will turn on if lid is not closed, so do not flip the switch with the lid open. The centrifuge will get to its top speed in a couple of seconds, which is usually a sufficient amount of time to spin down samples. Allow centrifuge to come to a complete stop before opening.



**Figure 17** – Mini centrifuge

## Thermocycler

A thermocycler, also known as a PCR machine, is a machine that performs regulated temperature cycles using a thermal block. The thermal block has slots for 0.2 mL PCR tubes and is paired with a heated lid. The machine can be programmed to incubate samples at reaction-specific temperatures for chosen amounts of time. As a Dependent Lab Worker, you will not be permitted to edit or create programs on the thermocycler. For that reason, this manual will only cover how to run an existing program on the thermocycler. These instructions are specific to our team's thermocycler in the iGEM lab.



How to run a program:

1. Turn on the power with the switch on the back of the machine. The machine will beep four times and carry out a self-test which could take between 1 and 2 minutes. If this test is successful, the machine will display the main menu, including the following:
  - a. In the top left corner of the main screen, the hot lid status is displayed.
  - b. The center of the screen displays Labnet, the software version number, block model, default file, default user, control mode, and sample volume.
2. Put your samples in the thermal block. Reaction temperature is most consistent in the center of the block. Make sure the lids of your tubes are securely closed.
3. Close the lid and turn the knob to lower the heated lid.
4. Press "File" (the F1 button) to enter the file list interface and scroll to the desired folder ("igem").
5. Press "Enter" to view programs in the "igem" file. Scroll to the desired program and press "Enter" again.
6. Press "Run" (the F5 button) to run the program.
7. Enter the sample volume in the pop-up window. The machine should start running.
8. When the program is done running, remove your samples and turn the thermocycler off with the power switch.



**Figure 18** – iGEM thermocycler

## Water bath

There are several water baths in G7 and the iGEM lab. To set the temperature on the water bath, first turn the machine on using the power switch. When the machine is on, press and hold the "set" button and press the up or down arrow to adjust the temperature. Turn the machine off when you are finished using it (but first check with others in the lab to ensure that they are not planning on using it since it takes a while to heat up).



**Figure 19** – iGEM water bath

## Stir Plate

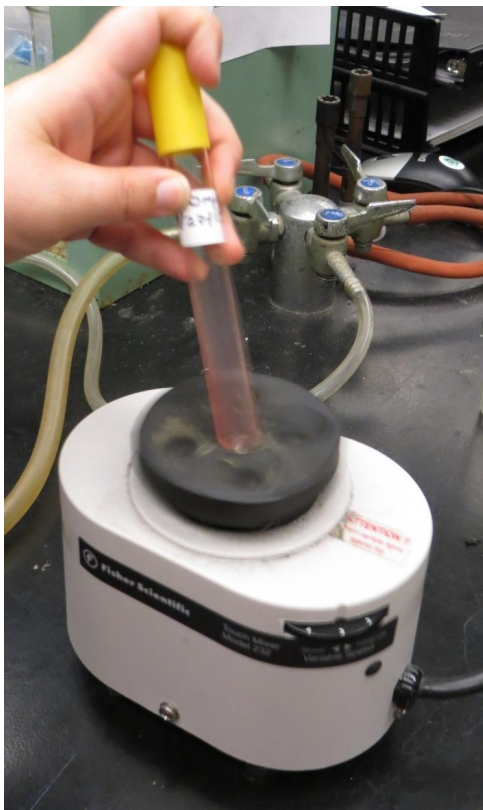
Magnetic stir plates mix solutions by rotating a magnetic stir bar that is placed into the solution. The iGEM stir plate does not have a heating function, so if the solution needs to be heated while stirring, a hot plate from another lab will need to be used. The knob on the side of the base is the only control on the stir plate. It is numbered from 0 (off) to 10 (highest stir speed). Your vessel should be centered on the plate. It may be necessary to gradually increase the rate of stirring if the stir bar skips around in the container. Always turn off the machine when you are done using it.

## Vortexer

The vortexer is used to vigorously mix samples. This should not be used for samples that require gentle mixing. The dial controls the shaking speed of the platform. The platform will not

begin shaking when the dial is turned; the platform must be pressed down to induce shaking. After setting to the correct intensity, gently press sample tube into platform groove to initiate vortex action. To turn the machine off, turn the dial to the off position.

The vortex is often used with glass culture tubes and 1.5 mL Epi tubes. When using the vortex for glass culture tubes, it may be necessary to start with a low intensity and work up to the appropriate intensity to avoid spilling or contaminating your culture.



**Figure 20** – Vortexing vortexer

### Microwave

There is one microwave in G6 that is for laboratory use only. You should not use this microwave for food. It operates like a standard microwave. It is advisable to heat in short intervals

and mix frequently. There are orange silicone hot mitts that you should use when handling hot glassware from the microwave.

Commented [L8]: Change, new lab microwave



Figure 21 – Silicone hot mitt and microwave

## Incubators

There are two types of incubators that iGEM uses: shaking and stationary. There are two of each type of incubator. The stationary incubators are in G7A and are set at 37°C and 30°C. There is a shaking incubator in G7A set at 30°C and a shaking incubator in G7 set at 37°C. Shaking incubators are used to agitate liquid media and typically are not used for solid media. The stationary incubator can be used for both solid and liquid media. The settings displays on both shaking incubators show the rpm and temperature.

When using the incubators:

- Keep them closed as much as possible to maintain the incubation temperature.
- After you are done accessing the incubator, make sure the doors are securely closed. If using a shaking incubator, make sure the platform resumes rotation.
- Do not adjust any of the incubators' settings.
- Make sure that your samples are sufficiently labeled and (in the case of a shaking incubator) effectively secured.
- Make sure all samples are securely closed.

## NanoDrop

iGEM uses the NanoDrop in Dr. Shannon's lab. This lab is only open from 8 am to 4 pm, Monday through Friday. Keep this in mind when you might need to use the NanoDrop. A key to Dr. Shannon's may be made available to Instructors, Assistant Instructors, and Independent Lab Workers in the event that we need to access the NanoDrop outside of these hours.

A NanoDrop measurement is done with a purified sample of DNA, such as the product of a miniprep. This equipment is used to determine the purity and concentration of a sample of DNA. Knowing the concentration of DNA is important for many reactions.

### NanoDrop procedure for measuring DNA concentration

1. Using a 20  $\mu$ L pipette, deposit a 2  $\mu$ L drop of MilliQ water on the sample pedestal and lower the sampling arm into the "down" position. Raise the sampling arm and wipe off water with a Kim-wipe to clean the pedestal surfaces from any dried material.
2. Open the NanoDrop program and the appropriate module (e.g., DNA or nucleic acid).
3. Load a blank sample of 2  $\mu$ L (the buffer, solvent, or carrier liquid used with your DNA samples) onto the sample pedestal and lower the sampling arm into the "down" position.
4. Click on the "Blank" (F3) button in the Application module.
5. Wipe the blanking solution from both pedestal surfaces with a Kim-wipe.
6. Load 2  $\mu$ L of your sample. Lower the sampling arm.
7. Click "Measure" and record the concentration, the 260/280 ratio, and the 260/230 ratio displayed on the screen. For DNA, the peak should be at 260 nm. The 260/280 ratio should be between 1.8 and 2.0. The 260/230 ratio should be over 2.0.
8. To test multiple samples, wipe the pedestal surfaces in between measurements with a Kim-wipe. Recalibration or re-blanking is not necessary.
9. Clean the pedestal surfaces with MilliQ water after you are finished.

### Interpreting Results

- **260/280:** ratio of sample absorbance at 260 and 280 nm. The ratio of absorbance at 260 and 280 nm is used to assess the purity of DNA or RNA. A ratio of approximately 1.8 is generally accepted as "pure" for DNA; a ratio of approximately 2.0 is generally accepted as "pure" for RNA. If the ratio is appreciably lower in either case, it may indicate the presence of protein, phenol or other contaminants that absorb strongly at or near 280 nm.
- **260/230:** ratio of sample absorbance at 260 and 230 nm. This is another measure of nucleic acid purity. The 260/230 values for "pure" nucleic acid are often higher than the respective 260/280 values. The 260/230 ratio is commonly in the range of 2.0-2.2. If the ratio is appreciably lower, this may indicate the presence of co-purified contaminants (which absorb at 230 nm), such as salts.

- **ng/μL:** nucleic acid concentration in ng/μL based on absorbance at 260 nm and the selected analysis constant.

This is what a sample containing DNA should look like:

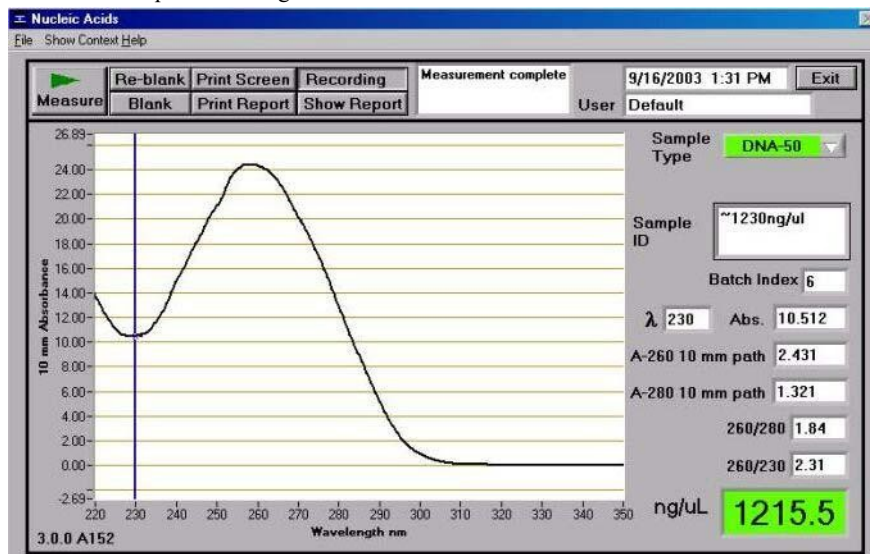


Figure 22 – DNA NanoDrop screen

## Electroporator

This machine uses electricity to transform cells with DNA. The power switch is on the front of the machine in the lower left corner. A cuvette is placed in the electroporator by lining up the notch on the cuvette with the shape of the cuvette slot. The cuvette will **not** go all the way down into the slot (as shown in Figure 23). **If you try to force the cuvette all the way down, you will break the electroporator.** For full instructions on how use the electroporator to perform an electrical transformation, see the Electrical Transformation section.



**Figure 23** – iGEM lab electroporator with cuvette

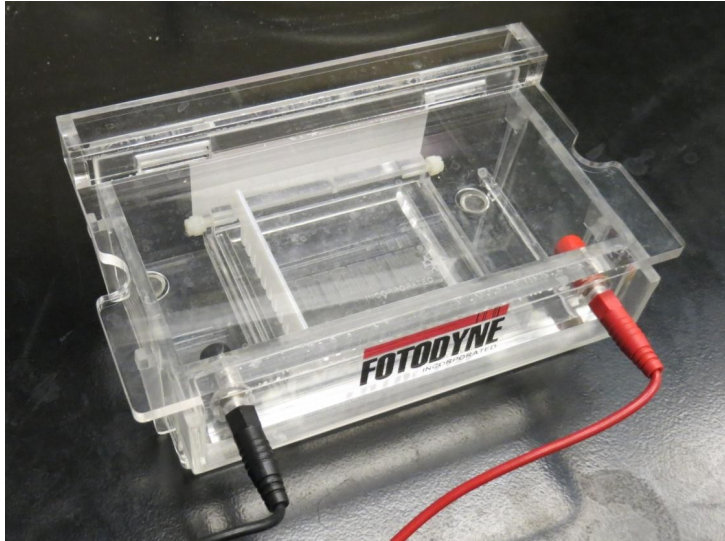
### Gel Electrophoresis Chamber

Gel electrophoresis is used to separate molecules by size or charge. The equipment used in the iGEM lab for gel electrophoresis includes an electrophoresis chamber with an interlocking lid, gel trays with casting gates, combs, and a power supply. For full instructions on how to use a gel electrophoresis chamber to perform gel electrophoresis, see the Gel Electrophoresis section.

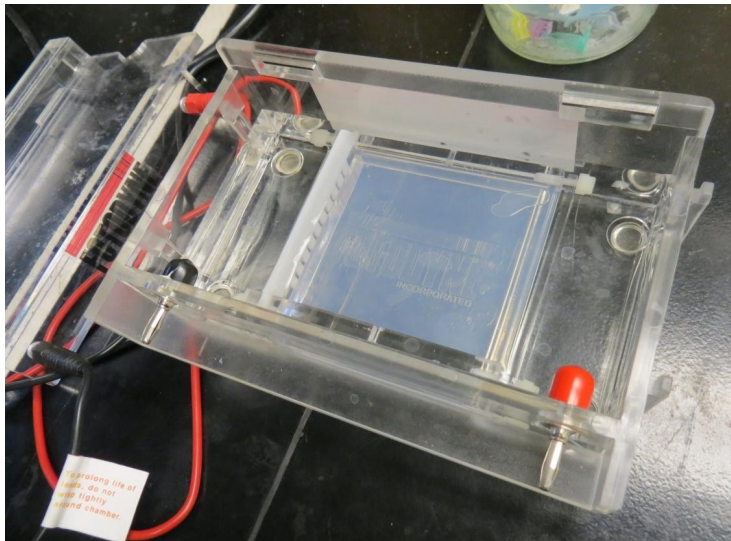


**Figure 24** – iGEM gel electrophoresis power supply





**Figure 25** – iGEM gel electrophoresis chamber



**Figure 26** – iGEM gel electrophoresis chamber with agarose gel



## Transilluminator

Transilluminators (also called UV light boxes) emit UV light that can be used to visualize fluorescent dyes. Transilluminators are commonly used to visualize DNA that has been run on a gel with ethidium bromide. There are two transilluminators available to iGEM labworkers: one in G7A and one in G7. The transilluminator in G7A has a digital camera system that is connected to a computer and is used to capture photographs of gels. The other transilluminator is in G7 and has a protective shield but no camera.

While exposed to UV light from the transilluminator, it is **absolutely necessary** to wear a protective face shield to protect your face and eyes from the UV light that is emitted from the machine. When using the transilluminator in G7, make sure the shield stays between you and the UV light source. You should also minimize UV exposure to the DNA on the transilluminator because the UV light will quickly damage the DNA. Use the low power setting when extracting DNA and the high power setting **only** when capturing an image.



Figure 27 – G7 transilluminator with protective shield



Figure 28 – G7A Transilluminator



**Figure 29** – G7A Transilluminator with digital camera system

#### Capturing a Photograph Using the G7A Transilluminator

1. After running a gel, gently remove it from the casting tray and place the gel in the middle of the platform of the transilluminator.
2. If desired, look at the gel using the low power setting. Don't forget to wear a protective face shield.
3. Place the digital camera system over the transilluminator platform, completely covering the UV light source.
4. Log into your S&T student account. The computer might take a couple minutes to load if it is your first time using this computer.
5. Open the imaging program by double-clicking the PC Image icon on the desktop.
6. Click the "Acquire New Image" button (camera icon) in the upper left corner of the program window. The "Image Capture" menu should appear on the screen.
7. Switch the power button on the transilluminator (bottom left corner) to the "High" setting. Make sure the light source is completely covered before turning on the UV light. A live image of the gel should appear on the computer screen.
8. Adjust the aperture, zoom, and focus if necessary. These are adjusted by turning the rings on the top of the digital camera system.
9. In the "Image Capture" menu, click the "Capture" button.

10. Switch the power button on the transilluminator (bottom left corner) to the "Off" setting.
11. Adjust the brightness and contrast of the picture if necessary. These scales are found in the "Image Capture" menu. You can also insert text boxes and draw shapes on the image if desired.
12. Save the image of the gel with the filename "MM/DD/YYYY Gel #" on the iGEM flashdrive. Also email the gel picture to the Lab Manager.
13. Close the program and log off of the computer. If excising DNA fragments, see the instructions below. When you are finished with your gel, dispose of it in the regular trash and **wipe down the transilluminator platform with ethanol.**

#### Excising a DNA Fragment Using a Transilluminator

1. Place the gel on the transilluminator platform. The transilluminator in G7 or G7A will work for this procedure. If using the G7A transilluminator, **wear a protective face shield.** If using the G7 transilluminator, **keep the attached protective shield between you and the UV light source at all times.**
2. Appropriately label the 1.5 mL Epi tube that will be used to store the gel slice containing the DNA fragment of interest.
3. Turn on the UV light to the lower setting. Remember that it is important to minimize UV exposure time and intensity to the DNA.
4. Center a sterile straw over the DNA band of interest and press the straw all the way through the gel. It may be necessary to slightly angle the straw, as DNA bands are not always vertical.
5. Remove the straw with a scooping motion such that the gel slice is removed from the gel in the end of the straw.
6. Gently squeeze the gel slice out of the straw and into your labeled 1.5 mL Epi tube. You are now ready to purify your DNA through gel extraction (see Gel Extraction section).
7. When you are finished with your gel, dispose of it in the regular trash and **wipe down the transilluminator platform with ethanol or distilled water.**